



SANITARY WARE • PORCELAINE SANITAIRE

## T-0027SF (A-002) (ADA Toilet)

### One-piece toilet

### Toilette monopièce



### PERFORMANCE

KIOO's low consumption toilets are designed with a powerful siphon jet flush system. They also offer a large water surface and glazed trapway. They all meet or exceed the following specifications.

Les toilettes à faible consommation d'eau de KIOO sont conçues avec un puissant système d'évacuation à siphon. Elles offrent aussi un grande surface d'eau et un drain verni, en plus de rencontrer ou d'excéder les spécifications suivantes.

### SPECIFICATIONS | SPÉCIFICATIONS

WATER USE UTILISATION D'EAU	4/6Lpf (1.1/1.6 Gpf) 4/6LPF (1.1/1.6 GPF)
FLUSH SYSTEM SYSTÈME D'ÉVACUATION	3" flush valve (clapper)   1000 g Valve d'évacuation de 3" (clapet)   1000 g
FLUSH BUTTON BOUTON DE LA CHASSE	Polished chrome knob push on top Bouton au fini chrome poli placé sur le dessus
TRAPWAY DIAMETER DIAMÈTRE DU SIPHON	2" siphon (ø50 mm)
ROUGH-IN DRAIN D'ÉVACUATION	12" (305 mm)
MATERIAL MATÉRIEL	Vitreous china   Water absorption under 0.5% Porcelaine vitrifiée   Absorption d'eau sous 0.5%
SEAT SIÈGE	Soft-close feature included   Quick-Release feature (removable) Fermeture progressive incluse   Amovible
TRAPWAY TYPE TYPE DE SIPHON	Concealed Dissimulé
BOWL TYPE TYPE DE CUVE	Rounded Arrondie



**Caution: Use proper support to mount product.**

**Attention: Utilisez un support approprié pour installer le produit.**

Fixture dimensions and hydraulic performance meet or exceed CSA requirements. Les dimensions du produit et sa performance hydraulique rencontrent ou excèdent les exigences du CSA.

These dimensions and specifications are subject to change without notice. Ces dimensions et spécifications sont sujettes à changement sans préavis.

## CAMICK

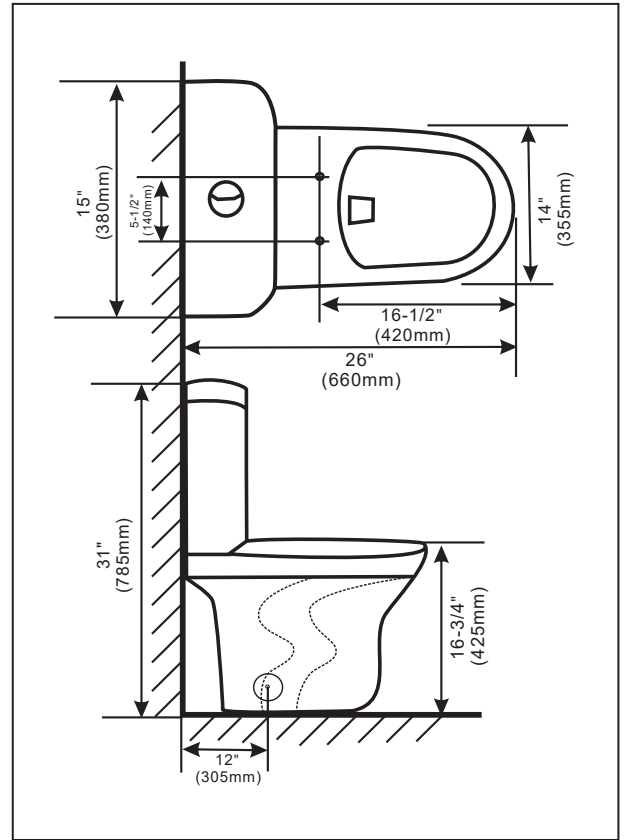

### INCLUDED | INCLUS



Seat | Siège  
RP-TS392SFQ



Parts | Pièces  
Input valve | Valve d'entrée  
RP-FIV009

Output valve | Valve de sortie  
RP-FSV026

Flush lever | Clanche  
RP-CL021



CUPC FILE NO.: 9531

WATER SENSE (HET) FILE NO: 9530

CERTIFIED MODEL: GF-A002

For more information, visit our website at [bathdepot.ca/kioo-brand](http://bathdepot.ca/kioo-brand)

Pour plus d'informations, visitez notre site web à [baindepot.com/marque-kioo](http://baindepot.com/marque-kioo)

Rev. March 16, 2022

# INSTALLATION INSTRUCTIONS | INSTRUCTIONS D'INSTALLATION

Work Preparation: Remove the inoperative tank fittings and carefully clean the water cistern/tank. Make sure all debris has been removed prior to installing new tank fittings.

- Note : 1. This device is not intended to be used as retrofit device for 1.28 gpf water closet.  
2. Performance may vary since product was not tested on all models of water closets

<p>Flush valve installation</p>	<p>One piece flush valve installation</p>				<p>Use a screwdriver with less than 25kgf.cm (for reference only) torque to tighten the valve sufficiently to avoid leakage.</p>		
<p>Two piece flush valve installation</p>	<p>Remove nut.</p>		<p>Use with less than 14 N.m torque (for reference only) to tighten the valve sufficiently to avoid leakage.</p>		<p>Place the flat surface of the rubber gasket over the flush valve shank to sit flush with the ceramic surface. Make sure there is no potential for leakage between the tank and the base.</p>		
<p>Installation of push button</p>	<p>I. Installation of push button with screw and nut</p> <p>half push plate full push plate</p>		<p>Adjust valve clockwise or counterclockwise to insure rod aligns and falls on push plate.</p> <p>If the rod is too short or long, move the rod by turning it up or down to obtain a suitable position then tighten it with the adjusting nut.</p>				
<p>Installation of push button</p>	<p>II. Installation of push button with "U" lock</p> <p>Dismount the bolt and "U" lock with a screwdriver</p> <p>Insert push button to lid hole. Place the "U" lock under the tank lid and turn to tighten.</p> <p>half push plate full push plate</p>		<p>Adjust valve clockwise or counterclockwise to insure rod aligns and falls on push plate.</p> <p>If the rod is too short or long, move the rod by turning it up or down to obtain a suitable position then tighten it with the adjusting nut.</p>				
<p>Refill tube installation and adjustment</p>	<p>Note: A refill tube is optional based on the user's requirements</p> <p>1 Error if lower than water level</p> <p>2 Refill tube should be positioned higher than water level.</p>		<p>Instructions</p> <ol style="list-style-type: none"> <li>Please read carefully the following installation instructions in order to avoid component damage or injury to the installer.</li> <li>The instructions have been composed based in the latest product specifications. We reserve the right to make modifications to the packaging and specifications without providing prior notification.</li> <li>When installing the fill valve, the critical level on the fill valve (identified on the valve marked "CL") should be at least 1" (25.4mm) above the top of the overflow pipe of the flush valve. This is a plumbing code.</li> <li>We shall not be responsible for failures that are contributed to the use of parts other than those specified.</li> <li>Water Temperature: 2°C to 45°C</li> <li>Water Pressure Range: 0.02Mpa (0.2 Bar) to 0.8Mpa (8 Bar)</li> </ol> <p>DO NOT USE OR DROP ANY CHLORINE OR ANY CHEMICAL RELATED COMPONENTS. USE OF SUCH PRODUCTS WILL RESULT IN DAMAGE TO TANK COMPONENTS AND MAY CAUSE FLOODING AND PROPERTY DAMAGE AND VOID WARRANTY. DO NOT OVERTIGHTEN NUTS, OR TANK/BOWL MAY CRACK.</p>				
<p>Adjustment of flush volume</p>	<p>I. Adjustment of full flush volume</p> <p>full flush adjuster</p> <p>02</p> <p>Full adjuster up, full flush volume decreases. Full adjuster down, full flush volume increases.</p>		<p>II. Adjustment of half flush volume</p> <p>half adjusting float</p> <p>without buckle with buckle</p> <p>Note: When half adjuster is used to adjust partial volume, half adjusting float must be set at scale 1 or over 2.</p> <p>04</p> <p>Half adjuster up, half flush volume decreases. Half adjuster down, half flush volume increases.</p> <p>Float up, half flush volume decreases. Float down, half flush volume increases.</p> <p>half flush adjuster</p>				
<p>Troubleshooting</p>	<p>Little or no flush volume when the push button is activated.</p>	<p>Full flush or half flush water level is too high or too low.</p> <p>Readjust half adjusting float, half adjuster or full adjuster.</p>	<p>Leaking</p> <p>1 Rod to push button is too long. Cut a small portion, then readjust. Note: cut the upper end of the rod.</p>	<p>2 Debris in water is affecting the valve. Remove, clean and reassemble.</p> <p>The valve and base do not fit properly. Please remove and then reassemble.</p>	<p>3 One piece flush valve does not properly fit. Adjust gasket so the flat end is seated flush with the ceramic.</p>	<p>4 Two piece flush valve does not properly fit. Adjust gasket so the flat end is seated flush with the ceramic.</p>	

# INSTALLATION INSTRUCTIONS | INSTRUCTIONS D'INSTALLATION

## Installation Guide

### 1 Parts

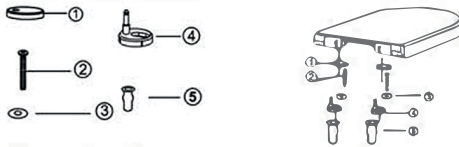

NO.	Description	Qty
1.	Stainless Steel Hinge cap	2
2.	Bolt	2
3.	Washer	2
4.	Hinge Base	2
5.	Rubber Cork	2

### 2 Installation Guide

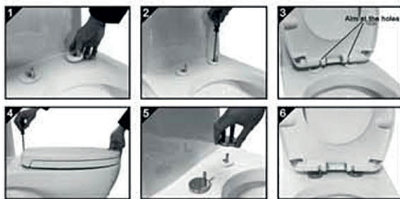

1. Insert the screw set on the hinge base through the holes on the pan.
2. Tighten the seat screws, but not fully allowing you movement to adjust the seat cover properly.
3. Aim at the holes and adjust the hinge base to make the seat cover and pan match. Take out the seat cover once the installation position is confirmed.
4. Fix the hinge base on the pan firmly.
5. Put the cap into the hinge base.
6. Fix the seat cover into the hinge base.

## SOFT-CLOSE SEAT COVER



### 3 Innovation Functions

ENTIRELY NEW SUPPORT MAKES YOUR ROOM TIDY AND CLEAN



Free rotation

Easy Installation

Fast lift & clean



Slow Close & Longer Life



Integrated Design and Strong Enough to last



Neatness and Clean Smooth Surface

Please abide by the following illustrations to ensure safety

Please read this notice carefully before operation. This manual lists many different kinds of warning marks to avoid injury to your body or loss or damage of property. The marks and explanations are as follows, please keep in plain sight.

**Warning!** It may cause injury to your body or property damage if you ignore this mark.  
● means "forbidden".

Warning!		Do not stand on the toilet cover, and do not place heavy objects on it. (this may cause cracking)	
		Do not clean the toilet seat with household cleaners, volatile thinner and eradicator, or use nylon brush and avoid chlorine-containing, corrosive and a abrasive cleaners. Maintain the shiny surface by using soft fabric and clean water. (Or else it may cause abrasion or crack.)	
		Do not let children play with the toilet cover, to avoid trapped or hurt fingers and other accidents	

### 4 Relative Notice

Open and close the toilet seat cover tenderly (or this may cause this to crack)

Avoid sunlight and other artificial light sources (or this may affect the colour)



- Both the toilet seat and cover have the function of slow closing
- The closing speed varies dependent on room temperature and usage frequency
- Please open the toilet seat and cover completely, otherwise the functionality of slow closing will fall and may cause injury to fingers or other body parts

### 5 Maintenance

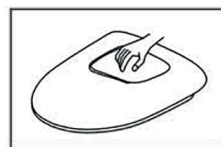

1. Periodical maintenance
- Wipe gently with wet fabric.
  - Wipe off dirt
- Wash this with neutral cleaners (such as soap powder) gently drying with clean fabric

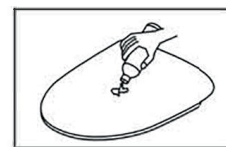

2. Cleaners
- Do not wipe or wash the toilet seat and cover with abrasive powder or cleaning products
  - Do not use disinfectant, germ cleaner or other aerosol cleaners
  - Please note that some chemical and caustics used in the bathroom may damage the toilet seat and cover

# INSTALLATION INSTRUCTIONS | INSTRUCTIONS D'INSTALLATION

Refill tube (A refill tube is optional based on the user's requirements)

The height of "H" & "L" doesn't include the height of triangle seal.

9" fill valve pipe H adjustable range 198-273mm L adjustable range 87-227mm  
 10" fill valve pipe H adjustable range 218-313mm L adjustable range 107-267mm  
 11" fill valve pipe H adjustable range 243-338mm L adjustable range 132-292mm

**Instructions**

- Please read carefully the following installation instructions in order to avoid component damage or injury to the installer.
- The instructions have been composed based in the latest product specifications. We reserve the right to make modifications to the packaging and specifications without providing prior notification.
- When installing the fill valve, the critical level on the fill valve (identified on the valve marked "CL") should be at least 1" (25.4mm) above the top of the overflow pipe of the flush valve. This is a plumbing code.
- We shall not be responsible for failures that are contributed to the use of parts other than those specified.
- Water Temperature: 2°C to 45°C
- Water Pressure Range: 0.02Mpa (0.2 Bar) to 0.8Mpa (8 Bar)

**Warning**

DO NOT USE OR DROP ANY CHLORINE OR ANY CHEMICAL RELATED COMPONENTS. USE OF SUCH PRODUCTS WILL RESULT IN DAMAGE TO TANK COMPONENTS AND MAY CAUSE FLOODING AND PROPERTY DAMAGE AND VOID WARRANTY. DO NOT OVERTIGHTEN NUTS, OR TANK/BOWL MAY CRACK.

**I Work Preparation:** Remove the inoperative tank fittings and carefully clean the water cistern/tank. Make sure all debris has been removed prior to installing new tank fittings.

## II Water Level Adjustment

### (1) Major Water Adjustments

1

Remove the clip as per the drawing.

2

Unscrew the fill valve body counterclockwise, push the body up or down to the desired height and refasten valve body by turning clockwise.

3

Install the clip as per drawing.

### (2) Minor Water Adjustments

1

Slide tab in the "OPEN" direction as shown in the drawing.

**Note on Float Adjustment**

Make sure that distance between float and shut-off cup is 0.5-2mm while at adjustment.

## III Fill Valve Installation

1

Unscrew the nut and remove both the plastic and rubber washer (optional).

2

Insert the fill valve into the installation hole at the bottom of the tank and then install the rubber and plastic washer (optional) and tighten hex nut. Installation torque recommendation:  
 1. Recommended torque for locknut with rubber washer and plastic washer or with plastic washer only is 4-6 N.M. (Newton Meters)  
 2. Recommended torque for locknut without rubber washer and plastic washer is 7-10 N.M. (Newton Meters)  
 Remark: Please observe if there is any leakage after installation. After tightening the nut, ceramic installation hole may distort and can result in leaking.

3

Insert the refill tube (optional) into the overflow pipe of the flush valve.

4

Turn on the water supply valve / angle stop.  
 Install water supply line onto the shank of the fill valve and turn on water supply valve/angle stop. Choose adaptor or wing nut based on actual requirement.

## IV. Cleaning Filter (Filter which is located inside the inlet valve shank is required for cleaning periodically)

1

Shut off the water supply valve (angle stop) then remove the water supply line from the inlet adaptor.

2

Remove the filter screen from the inner portion of the shank.

3

Picture for reference only. Clean the filter screen with water

4

Re-install clean filter back into the inner portion of the shank.

## V. Troubleshooting

Issue	Cause	Resolution
Water line is too high or too low	Inlet valve is not adjusted to a suitable position	Adjust the water level to the appropriate water level
Inlet valve does not shut off.	1) The cistern/tank wall has blocked the movement of the inlet valve float. 2) The refill tube wasn't installed properly 3) Leakage of flush valve. 4) The water level is above overflow pipe of flush valve.	1) Adjust the fill valve to the appropriate position and make sure float can move freely. 2) See figure attached to re-install refill tube correctly. 3) Make sure none leakage of flush valve. 4) Re-adjust water level and installation height to appropriate position.
Inlet valve does not turn on.	1) Water supply valve/angle stop is off. 2) The cistern/tank wall has blocked the movement of the inlet valve float. 3) Filter screen is dirty	1) Turn on the water supply valve/angle stop. 2) Adjust the fill valve to the appropriate position and make sure float can move freely. 3) Clean filter screen

### Installation of refill tube :

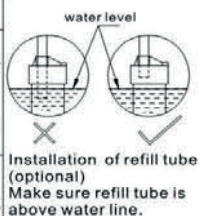

# INSTALLATION INSTRUCTIONS | INSTRUCTIONS D'INSTALLATION

## TOOLS AND MATERIALS REQUIRED / OUTILS ET FOURNITURES NÉCESSAIRES:

- A Water Supply Kit (Not needed if repalcing existing toilet)  
*Nécessaire d'arrivée d'eau  
(déjà en place dans le cas du remplacement d'une toilette)*
- B Adjustable Wrench / *Clé à molette*
- C Flathead Screwdriver / *Tournevis à lame plate*
- D Level / *Niveau*
- E Nut Driver or Socket Set / *Tournevis à douille ou jeu de douilles*
- F Putty Knife / *Couteau à mastic*
- G Tape Measure / *Ruban à mesurer*

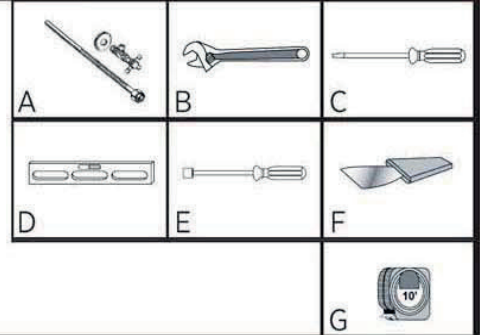

## 1. REMOVING YOUR OLD TOILET / DÉMONTAGE DE LA TOILETTE USAGÉE

- 1** Turn off the water supply.  
*Fermez l'arrivée d'eau.*
- 2** Flush the toilet to empty the tank. Remove any water left in the tank or bowl.  
*Actionnez la chasse d'eau pour vider le réservoir. Videz complètement l'eau qui reste dans la cuvette ou dans le réservoir.*
- 3** Disconnect the supply line from the tank.  
*Démontez la conduite d'arrivée du réservoir.*
- 4** Remove decorative caps. Unscrew nuts that attach the toilet to the floor.  
*Enlevez les capuchons décoratifs. Dévissez les écrous qui fixent la cuvette au plancher.*
- 5** Remove toilet.  
*Enlevez la toilette.*
- 6** Make sure the water supply valve is shut off before installation.  
*Assurez-vous que le robinet d'arrivée est bien fermé avant de procéder.*
- 7** Remove old closet bolts from closet flange. Clean any old wax, putty, etc. from base area.  
*Enlevez les vieux boulons de cuvette de la bride de fixation. Débarrassez la bride et le plancher de toute trace de cire, de mastic, de saleté.*

**IMPORTANT NOTE REGARDING WATER SUPPLY:** Before installation ensure that the shut-off valve is greater than 7½" from the center of the drain to the center of the shut-off valve on either side (Figure 1).

**NOTE:** This is a true 12" rough-in toilet from finished wall to center of the drain (no less than 12"). Baseboard thickness may reduce rough-in dimension.

**REMARQUE IMPORTANTE CONCERNANT L'ALIMENTATION EN EAU :** Avant d'installer la toilette, assurez-vous que le robinet d'arrêt soit à une distance de plus de 7 1/2 po du drain, d'un côté ou de l'autre de celui-ci (Figure 1).

**N.B. :** C'est une toilette dont le gros d'œuvre est vraiment de 12 po du mur fini jusqu'au centre du drain (pas moins de 12 po). L'épaisseur de la plinthe peut réduire la dimension du gros d'œuvre.

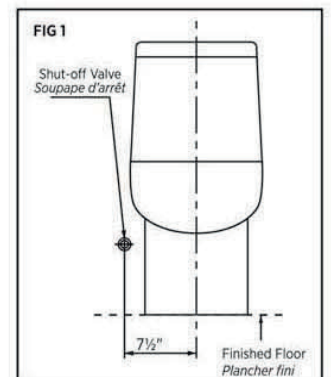

# INSTALLATION INSTRUCTIONS | INSTRUCTIONS D'INSTALLATION

## 2. ONE PIECE TOILET / TOILETTE MONO-PIÈCE

### INSTALLATION PROCEDURE / INSTRUCTIONS D'INSTALLATION

- 1** Install new floor bolts into floor flange. (Figure 2)

*Introduisez les boulons à plancher neufs dans la bride de fixation. (Figure 2)*

- 2** Attach flexible water supply line to the inlet of the fill valve and hand tighten only. **At this point, DO NOT connect to the water shut-off valve.** (Figure 3)

*Joignez la conduite d'arrivée d'eau flexible à l'orifice d'entrée du robinet de remplissage et serrez à la main seulement. À ce moment-là, NE connectez PAS le robinet d'arrêt. (Figure 3)*

- 3** Place a new wax ring around the waste flange of toilet bowl. (Figure 4)

*Mettez un nouvel anneau de cire sur la bride de vidage de la cuvette. (Figure 4)*

- 4** Lower the toilet onto the closet bolts, so the bolts project through mounting holes in base of toilet. (Figure 5) Using a rocking motion, press the bowl down to position the toilet onto the flange.

*Déposez la cuvette sur les boulons de cuvette de façon à ce que les boulons sortent des trous de fixation situés sur le socle de la cuvette. (Figure 5) D'un mouvement de va-et-vien, faites délicatement basculer la cuvette pour la placer sur la bride de fixation.*

- 5** Install plastic cap washers, followed by metal washers and nuts onto the closet bolts. (Figure 6) Tighten the bolts alternately until toilet is firmly seated on the floor.

**CAUTION: DO NOT OVERTIGHTEN NUTS, SEVERE DAMAGE MAY OCCUR**

*Posez tour à tour les rondelles et capuchons en plastique, les rondelles métalliques et les écrous sur les boulons de cuvette. (Figure 6). Serrez les boulons en alternant jusqu'à ce que la cuvette soit solidement fixée au plancher.*

**MISE EN GARDE : SERRER EXCESSIVEMENT LES ÉCROUS POURRAIT CAUSER DES DOMMAGES GRAVES.**

- 6** Install plastic cap covers.

*Posez les capuchons en plastique.*

- 7** Connect the flexible water supply line (not included) to the shut-off valve. Tighten coupling nut securely (Figure 7).

*Raccordez le tuyau d'alimentation d'eau flexible à la soupape d'arrêt. Resserrez l'écrou de couplage (Figure 7).*

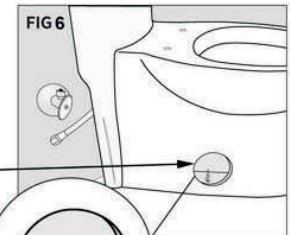
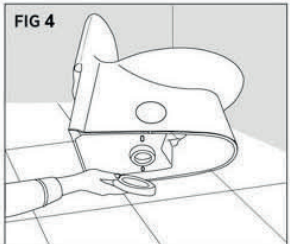
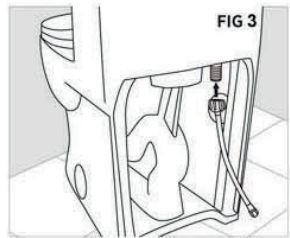
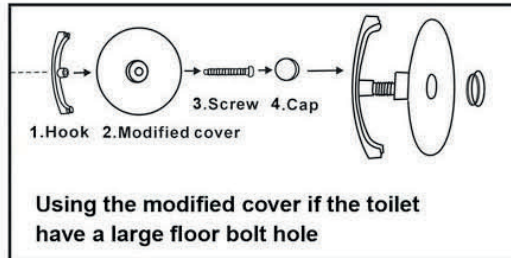
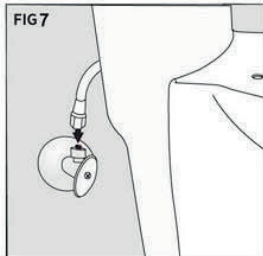

# INSTALLATION INSTRUCTIONS | INSTRUCTIONS D'INSTALLATION

## WATER SUPPLY / L'ALIMENTATION D'EAU

- 1 Turn on supply valve and allow tank to fill until float rises to shutoff position.  
*Ouvrir la soupape d'alimentation et laisser le réservoir se remplir jusqu'à ce que le flotteur monte à la position fermé.*
- 2 Check for leakage at fittings, tighten or correct as needed.  
*Vérifiez les fuites aux raccords, resserrez ou corrigez si nécessaire.*

## 3. TWO PIECES TOILET/ TOILETTES DE DEUX PIÈCES INSTALLATION PROCEDURE / INSTRUCTIONS D'INSTALLATION

- 1 Install new closet bolts into closet flange. (Figure 8) You can pre-cut the closet bolts to the desired length to put on the bolt cap by doing the following: Temporarily install closet bolts and set the toilet and place the washers and nuts onto the bolts. Then mark the length needed. Take toilet out of the place and remove the closet bolts. Cut the closet bolts to the length and then turn the toilet upside down onto a soft surface to avoid scratches on the finish.

*Introduisez les boulons de cuvette neufs dans la bride de fixation. (Figure 8) Les boulons de cuvette peuvent être coupés au préalable à la longueur voulue, de la façon suivante: Posez temporairement les boulons de cuvette, déposez la cuvette dessus, puis mettez les rondelles et les écrous sur les boulons. Marquez la longueur voulue. Enlevez la cuvette et les boulons. Coupez les boulons à la longueur désirée et déposez la toilette à l'envers, de préférence sur une surface douce afin d'éviter les éraflures sur le fini.*



- 2 Place a new wax ring around the waste flange of toilet bowl. (Figure 9)  
*Mettez un nouvel anneau de cire sur la bride de vidage de la cuvette. (Figure 9)*

- 3 Lower the toilet onto the closet bolts, so the bolts project through mounting holes in base of toilet. (Figure 10) Using a rocking motion, press the bowl down to position the toilet onto the flange.

*Déposez la cuvette sur les boulons de cuvette de façon à ce que les boulons sortent des trous de fixation situés sur le socle de la cuvette. (Figure 10) D'un mouvement de va-et-vien, faites délicatement basculer la cuvette pour la placer sur la bride de fixation.*

- 4 Install plastic cap washers, followed by metal washers and nuts onto the closet-bolts. (Figure 11) Tighten the bolts alternately until toilet is firmly seated on the floor.

**CAUTION: DO NOT OVERTIGHTEN NUTS, SEVERE DAMAGE MAY OCCUR**  
*Posez tour à tour les rondelles et capuchons en plastique, les rondelles métalliques et les écrous sur les boulons de cuvette. (Figure 11). Serrez les boulons en alternant jusqu'à ce que la cuvette soit solidement fixée au plancher.*

**MISE EN GARDE : SERRER EXCESSIVEMENT LES ÉCROUS POURRAIT CAUSER DES DOMMAGES GRAVES.**

- 5 Install the flange bolt caps. (Figure 11)  
*Posez les capuchons sur les boulons de cuvette. (Figure 11)*

- 6 Insert tank bolts inside the tank. Use the metal and rubber washers supplied to create a seal. (Figure 12)

*Introduisez les boulons du réservoir dans le réservoir. Utilisez les rondelles en métal et en caoutchouc pour créer un joint étanche. (Figure 12).*

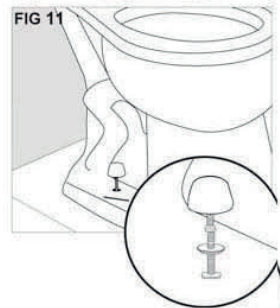
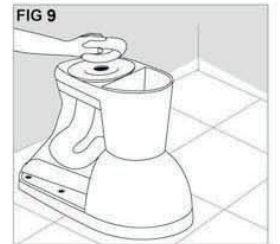

## INSTALLATION INSTRUCTIONS | INSTRUCTIONS D'INSTALLATION

- 7** Install the metal nut and washers on the bolts under the tank. Tighten the nuts until the rubber washers in the tank create a proper and secure seal.

*Posez les écrous métalliques et les rondelles sur les boulons sous le réservoir. Serrez les écrous jusqu'à ce que les rondelles situées à l'intérieur assurent l'étanchéité de l'assemblage.*

- 8** Attach the large rubber sealing gasket to the center drain hole under the tank. (Figure 13)

*Fixez le gros joint d'étanchéité en caoutchouc dans le trou de vidage central sous le réservoir. (Figure 13).*

- 9** Gently place the tank on the bowl with the bolts protruding out underneath. Then tighten with metal oval washers and wing nuts, tighten enough that the tank sits flat on the bowl.

*Déposez délicatement le réservoir sur la cuvette en introduisant les boulons dans les trous. Serrez avec les rondelles ovales et les écrous à oreilles suffisamment pour que le réservoir repose bien à plat sur la cuvette.*

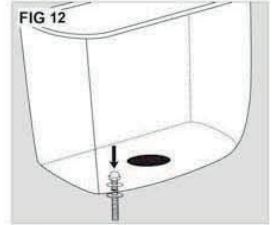

- 10** Make sure that the toilet tank is parallel to the wall and straight on the bowl.  
**CAUTION: DO NOT OVERTIGHTEN NUTS, SEVERE DAMAGE MAY OCCUR.**

*Assurez-vous que le réservoir est bien parallèle au mur arrière et aligné sur la cuvette.*

**MISE EN GARDE: SERRER EXCESSIVEMENT LES ÉCROUS POURRAIT CAUSER DES DOMMAGES GRAVES.**

### CONNECT WATER SUPPLY / RACCORDER L'ALIMENTATION D'EAU

- 1** Connect water supply line (new or existing) between shutoff valve and tank inlet water fitting. Tighten coupling nuts securely.

**NOTE: DO NOT OVERTIGHTEN**

*Raccordez le tuyau d'alimentation d'eau (nouvel ou existant) entre la soupape d'arrêt et le raccord d'entrée d'eau du réservoir. Resserrez les écrous de couplage.*

**N.B.: NE SERRER PAS EXCESSIVEMENT**

- 2** Turn on supply valve and allow tank to fill until float rises to shutoff position.

*Ouvrir la soupape d'alimentation et laisser le réservoir se remplir jusqu'à ce que le flotteur monte à la position fermé.*

- 3** Check for leakage at fittings, tighten or correct as needed.

*Vérifiez les fuites aux raccords, resserrez ou corrigez si nécessaire.*



## INSTALLATION INSTRUCTIONS | INSTRUCTIONS D'INSTALLATION

**4. TANK FITTING INSTALLATION & ADJUSTMENT PLEASE REFER TO THE INSTRUCTION MANUAL PUT INSIDE THE TANK**  
*Pour l'installation et l'ajustement du réservoir, référez-vous au manuel d'instructions placé dans le réservoir*

### 5. TOILET SEAT INSTALLATION INSTRUCTION

*Instruction du siège de toilette*

#### Installation Guide / Guide d'installation

##### Under locked / Barrure sous-plan

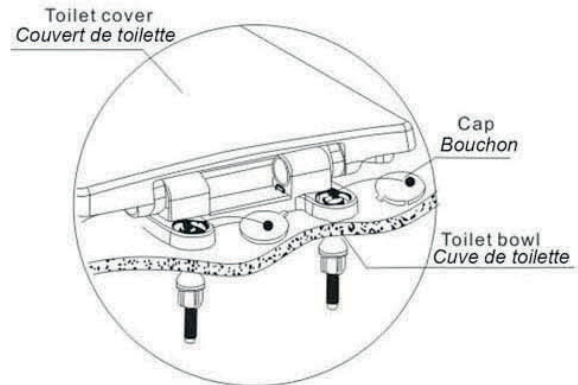
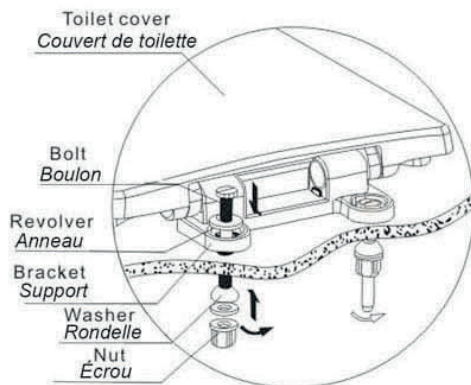

1. Insert revolver, washer and bolt into the installing hole.  
*Insérez l'anneau, la rondelle et le boulon dans le trou d'installation*

2. Insert the nut into the two holes perfectly and screw it with screwdriver, then put the cap on it.  
*Insérez parfaitement les écrous dans les deux trous d'installation et vissez à l'aide d'un tournevis. Ensuite, mettez les bouchons par-dessus.*

##### Above locked / Barrure sur-plan

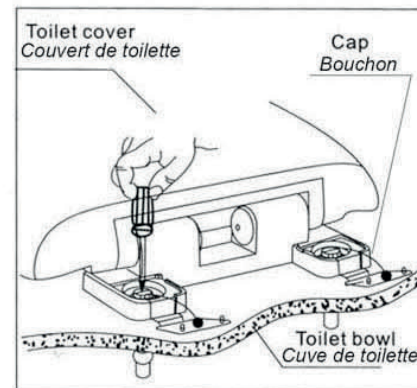
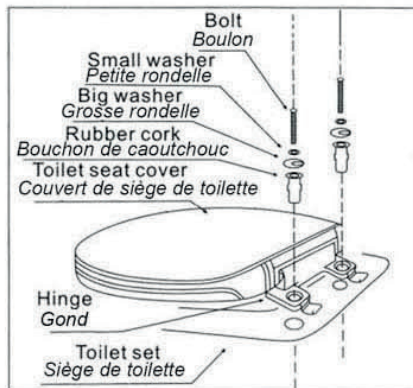

1. Place the toilet seat cover on bowl, insert the bolt, washer and rubber cord in hinge install hole-order;  
*Placez le siège de toilette, insérez les boulons, rondelles et bouchon de caoutchouc dans les gonds;*
2. Adjust position of toilet seat cover to match toilet set suitably after insert rubber cord into toilet install hole;  
*Ajustez la position du siège de toilette sur l'ensemble de toilette puis insérez les bouchons de caoutchouc dans les trous d'installations de la toilette.*
3. Tighten the bolt and close the hinge cover;  
*Serrez les écrous et fermez les couverts des gonds*
4. Insert the nut into the two holes perfectly and screw it with screwdriver, then put the cap on it.  
*Insérez parfaitement les écrous dans les deux trous et vissez avec un tournevis. Ensuite, placer les couverts dessus*

# INSTALLATION INSTRUCTIONS | INSTRUCTIONS D'INSTALLATION

Please abide by the following illustrations to ensure safety  
*S'il vous plait, respectez les illustrations suivantes pour assurer votre sécurité*

Please read carefully the relative notice before operation.

This manual lists many kinds of marks in detail to avoid injuring body, or suffering loss on property. The marks and explanations are as follows, please keep it in the eyeable place.

*S'il vous plait lisez attentivement l'avis concerné avant manipulation.*

*Ce manuel décrit en détail certain point pour prévenir les préjudices ou souffrance corporels. Ces avis et explications vont comme suit, s'il vous plait gardez dans un endroit visible.*



**Warning!** It may cause injuring body or damaging object if ignore this mark.

**Attention!** *Peut causer des préjudices corporels ou endommager des objets si vous ignorez cet avis*

● means "forbidden".



**Warning!**  
**Attention!**



Do not stand on the toilet cover, and do not place heavy objects on it. (Or else it may cause crack.)

*Ne pas monter sur le siège de toilette et ne pas y placer des objets lourds. (Sinon peut causer des craquelures)*



Do not clean the toilet seat with household cleaners, volatile, thinner and eradicator, or use nylon brush, and avoid chlorine-containing, corrosive and abrasive cleaners. Maintain the shiny surface by using soft fabric and clean water. (Or else it may cause abrasion or crack.)

*Ne pas nettoyer le siège de toilette avec des nettoyants domestique volatile, diluant ou détachant ou utiliser une brosse de nylon et éviter les nettoyants corrosifs, abrasif ou contenant du chlore. Entretenez les surfaces lisses en utilisant un tissu doux et de l'eau propre. (Sinon, peut causer des éraflures ou des craques)*



Do not let child play the toilet cover, to avoid hurting fingers and other accident.

*Ne laissez pas les enfants jouer avec le siège de toilette afin d'éviter les doigts coincés et autres accidents*



## Relative Notice / Avis relatif

Open and close toilet seat cover tenderly.  
(Or else it may cause crack.)

*Levez et abaissez le siège de toilette délicatement (Sinon peut causer des craquelures)*



Avoid sunlight and other lamp-house irradiate directly. (Or else it may turn colors.)

*Évitez l'exposition au rayon de soleil ou autre radiation direct de lampe domestique (Sinon peut causer un changement de couleur)*



- Toilet seat and cover both have the function of slow closing. *Le siège et le couvert de toilette ont, tout deux, la fonction de fermeture lente.*
- Closing speed varies for room temperature and usage frequency. *La vitesse de fermeture varie selon la température de la pièce et de la fréquence d'utilisation.*
- Please open toilet seat and cover completely, the function of slow closing will fail off in the midway, or hurt fingers etc. *S'il vous plait, ouvrez le siège et le couver complètement. La fonction de fermeture lente stagnera en mi-chemin ou tombera sur les doigts etc.*

## Maintenance / Maintenance

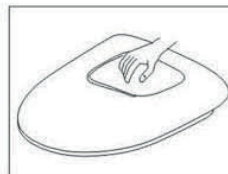

### 1. Periodical maintenance *Maintenance périodique*

- Wipe gently with wet fabric. *Essuyer délicatement avec un linge humide*
  - Wipe off smut *Essuyer la saleté*
- Wash it with neuter cleaners (such as soap powder), and then dry it with clean fabric.  
*Nettoyer avec un nettoyant neutre (comme de la poudre à laver) puis sécher avec un linge propre*

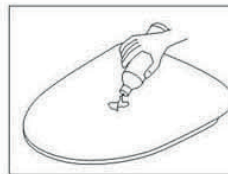

### 2. Cleaners *Nettoyants*

- Do not wipe and wash toilet seat and cover with abrasive powder. *Ne pas essuyer et laver le siège de toilette avec une poudre abrasive*
- Do not use disinfectant, eradicator or other aerosol cleaners. *Ne pas utiliser de désinfectant, détachant, ou autre nettoyant en aérosol*
- Some chemical and cosmetic in bathroom may damage toilet seat and cover. *Certains produits chimiques et cosmétique dans le salle de bain peut endommager le siège et couvert de toilette*

## GARANTIE LIMITÉE

En choisissant un produit KIOO, leader dans l'industrie de la plomberie, vous vous assurez de faire le bon choix. En plus des matériaux de qualité utilisés dans la conception de ses produits, ses procédés de fabrication évolués profitent aussi à leur qualité et leur longévité. C'est pour en faire foi que KIOO a décidé d'offrir une garantie avantageuse à sa clientèle.

Nous vous certifions que nos produits sauront satisfaire vos besoins grâce à leur style, mais aussi par leur qualité de fabrication. Afin de vous assurer fiabilité et sécurité, chaque produit a été minutieusement inspecté, testé puis approuvé lors d'un contrôle de qualité.

## À qui la garantie s'applique-t-elle?

KIOO offre une **garantie limitée de 5 ans** à partir de la date d'achat, exclusive au premier acheteur et tant qu'il réside dans la propriété. Cette garantie s'applique sur toutes les toilettes KIOO. La garantie est destinée à un usage résidentiel et/ou domestique.

## Consignes d'entretien

Le siège de toilette doit seulement être nettoyé à l'eau, à l'aide d'un détergent doux. Les détergents abrasifs ou corrosifs, la laine d'acier, les brosses de nylon, l'acétone, les produits de nettoyage à sec ou les composés d'ammoniac ne doivent jamais être utilisés pour nettoyer les surfaces du produit.

## Que couvre la garantie?

	1 an*	5 ans*
<b>Toilettes</b>	Système d'évacuation	Porcelaine
<b>Lavabos / Vasques</b>	Trop-plein et drain	Porcelaine
<b>Pièces</b>	Levier, valve, siège, capuchon, chaîne, joint d'étanchéité, vis, flexible, citerne encastrée et plaque de contrôle	—

\*À partir de la date d'achat

S'il y a des défauts de fabrication couverts par la garantie, le produit devra être inspecté avant de donner suite à toute réclamation. Sans cette vérification, aucun frais et/ou responsabilité ne seront assumés par la marque.

## Quelles sont les exclusions?

Cette garantie est applicable pour tous les produits KIOO achetés en date du 1<sup>er</sup> janvier 2018 ou après.

La garantie ne s'applique pas si le produit est endommagé suite à une utilisation non conforme, à un usage abusif ou non résidentiel, à de la négligence, à un manque d'entretien, ou en raison de l'utilisation de produits corrosifs ou abrasifs, et ce peu importe qui est responsable de ces dommages. La garantie ne couvre pas les frais d'expédition et de main-d'œuvre. KIOO ne couvre pas l'usure normale des composantes.

Dans le cas où l'alimentation en eau se fait à partir d'un puits, il se pourrait que le rendement du produit soit affecté, ce qui n'est pas couvert par la garantie.

La garantie ne couvre pas les dommages causés par les actes de Dieu ou les bris résultant d'un choc ou d'une mauvaise manutention, qu'elle fût de la part de l'acheteur ou de l'installateur. Elle exclut aussi les dommages qui résultent d'une mauvaise installation.

KIOO ne couvre pas les dommages aux biens causés par une fuite d'eau, que ceux-ci soient directement ou indirectement liés à un défaut du produit, sauf là où la législation applicable ne permet aucune exclusion ou limitation suite à des dommages indirects ou consécutifs.

Il est juste de préciser que s'il y a présence d'un défaut de fabrication sur le produit, il se manifestera dès l'installation ou peu de temps après. Par contre, si une fuite est causée par une mauvaise installation, elle ne pourra survenir que beaucoup plus tard. Il est donc fortement recommandé de faire appel à un professionnel.

**Toute demande de réclamation de garantie doit être accompagnée d'une copie de la facture.**

**Si une pièce ou composante du produit est défectueuse ou si le fini est endommagé dans le cadre d'un usage domestique et résidentiel normal, KIOO s'engage à remplacer, au premier acheteur uniquement, la ou les composantes défectueuses. KIOO pourrait aussi, et ce à son entière discrétion, s'engager à fournir un remplacement complet. Aucune indemnité ne pourra être réclamée suite à une perte de jouissance de la vie, à une perte de revenu ou aux pertes causées par l'eau.**

### LIMITED WARRANTY

By choosing a KIOO product, a leader in the plumbing industry, you are sure to make the right choice. On top of the quality materials that are used to make their products, KIOO's advanced manufacturing processes also benefit its products' quality and longevity. To attest to this, they decided to offer their customers a beneficial warranty.

We certify that our products will meet your needs with their style, but also with their manufacturing quality. To make sure that they are reliable and safe, each product was carefully inspected, tested and approved during the quality control process that is in place.

### To whom does this warranty apply?

KIOO offers a **5-year limited warranty** from the date of purchase, exclusive to the first buyer as long as he/she resides in the same property. This warranty applies to all KIOO toilets. The warranty is intended for residential and/or domestic use.

### Care instructions

The toilet seat must only be cleaned with water and a mild detergent. Abrasive or corrosive cleaners, steel wool, nylon brushes, acetone, dry cleaning products or ammonia compounds must never be used to clean the product.

### What is covered by the warranty?

	1 Year*	5 Years*
<b>Toilets</b>	Drainage system	Porcelain
<b>Bathroom Sinks / Vessel Sinks</b>	Overflow and drain	Porcelain
<b>Parts</b>	Lever, valve, seat, cap, chain, gasket, screws, flexible hose, concealed in-wall tank and control plate	—

\*From the date of purchase.

Should there be any manufacturing defects that are not covered by the warranty, the product will need to be inspected prior to following through with the claim. Without that verification, the brand will assume no charge and/or responsibility.

### What are the exclusions?

This warranty is applicable on all KIOO products purchased on or after January 1<sup>st</sup>, 2018.

The warranty doesn't apply if the product is damaged as a result of misuse, overuse or non-residential use, neglect, lack of maintenance, or the use of corrosive or abrasive products, regardless of the person who did those damages. The warranty does not cover shipping and labour costs. The warranty does not apply to the normal tear and wear of the goods.

In cases where the water supply is done through wells, the product's performance may be affected, which is not covered by the warranty.

The warranty doesn't cover the damages caused by the acts of God or breakage resulting from a shock or mishandling, regardless of the part played by the buyer or the installer. It also excludes the damages caused by an improper installation.

KIOO doesn't cover damages caused by a water leak, even if they result directly or indirectly from a product defect, except where the applicable legislation does not allow any exclusion or limitation following indirect or consequential damages.

It is fair to say that if the product has a manufacturing defect, it will show as soon as it is installed or shortly after. However, a leak caused by an improper installation could happen a long time after. Therefore, it is strongly advised to have it done by a professional.

**All warranty claims must include the invoice copy.**

**Should a part or product component be defective or the finish damaged following a normal domestic and residential use, KIOO commits to replacing the defective part(s) to the first buyer only. KIOO could also, in its sole discretion, commit to offer a full replacement. No indemnity shall be claimed for loss of enjoyment of life, loss of income or losses caused by water.**