

Shower Base Installation Manual Base de douche Manuel d'installation

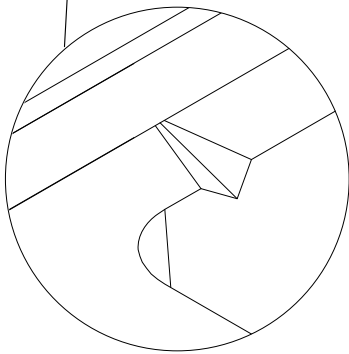

This indentation is designed to ensure the water goes back to the shower base, towards the drain.

Cette fente est conçue pour permettre à l'eau de retourner vers l'intérieur de la base de douche, vers le drain.

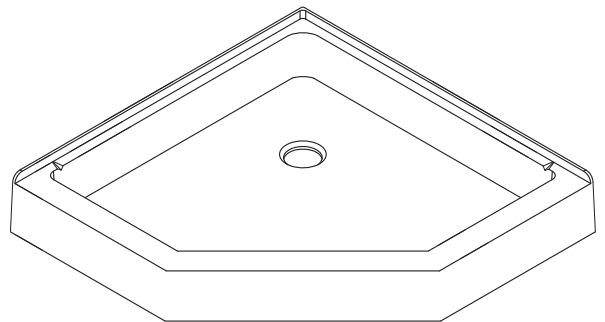
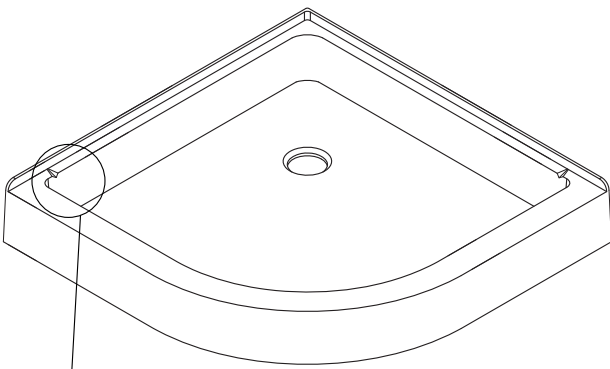
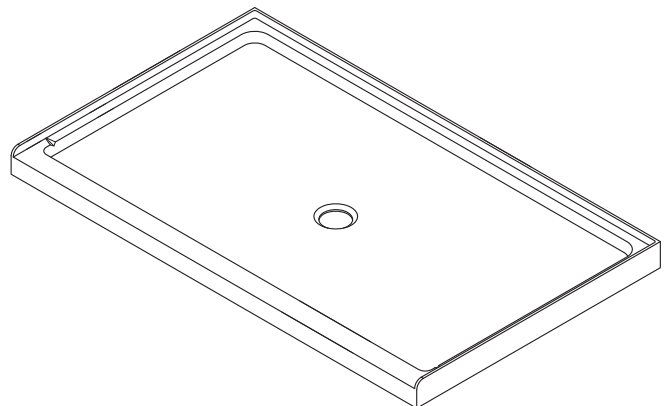
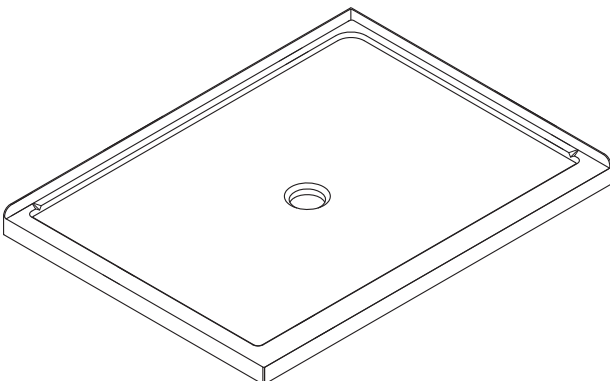

● IMPORTANT / IMPORTANT

1. Read this manual carefully and completely before proceeding.

* Lisez attentivement ce manuel au complet avant de continuer.

2. It is recommended that you wear safety glasses at all times during the installation

* Il est recommandé de porter des lunettes de sécurité en tout temps lors de l'installation

3. Prior to installation of base, all framing and plumbing work must be completed in accordance with this instruction sheet. For renovation work, existing shower surfaces must be removed to accommodate framing requirements. Ensure that outer wall are properly insulated, and that a vapor barrier has been installed in accordance with established building codes.

* Avant l'installation de la base, toute la charpente et les travaux de plomberie doivent être complétés conformément à la présente feuille d'instruction. Pour les travaux de rénovation, les surfaces murales existantes doivent être enlevées pour installer le cadrage exigé. Assurez-vous que les murs extérieurs sont isolés correctement et que le pare-vapeur a été installé conformément aux codes du bâtiment.

● Care for your Acrylic Shower Base / Prenez soin de votre Base de douche en acrylique

In order to protect the acrylic surface of your base, never use scouring powder pads or other strong solvent. Only clean with a mild detergent diluted in water or a detergent formulated specifically for acrylic.

Afin de protéger la surface en acrylique de votre base, ne jamais utiliser de tampons à récurer avec poudre ou tout autre solvant fort. Nettoyez avec un détergent doux dilué dans de l'eau ou un détergent formulé spécifiquement pour l'acrylique.

OUTILS ET MATÉRIAUX REQUIS / TOOLS AND MATERIALS REQUIRED

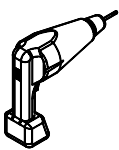

PERCEUSE
DRILL

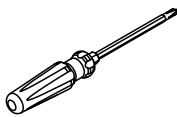

TOURNEVIS
SCREWDR

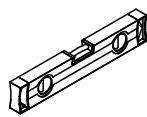

NIVEAU
LEVEL



COUTEAU DE PRECISION
PRECISION KNIFE



SILICONE
SILICONE

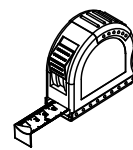

RUBAN À MESURER
MEASURING TAPE



CRAYON
PENCIL



FORETS: 1/8"
DRILLBITS: 1/8"



ESSUIE-TOUT
TOWELS



MORTIER
MORTAR

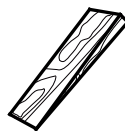

CALE
SHIM

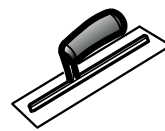

TRUELLE
TROWEL



ÉQUERRE
SET SQUARE



MAILLET
MALLET

BS-RD3601

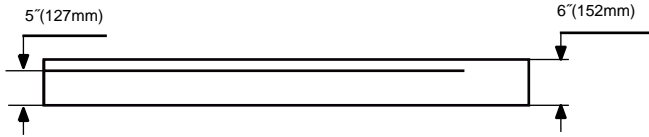
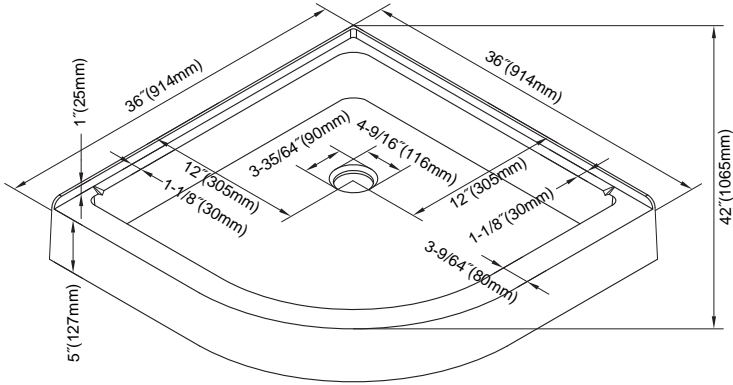

BS-RD533601

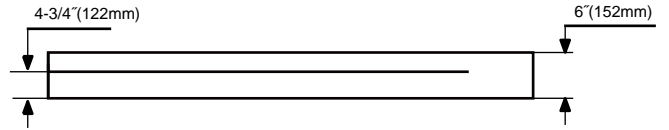
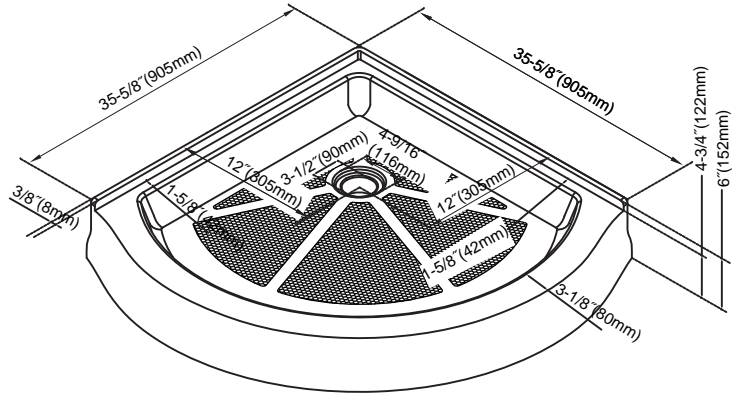

BS-RD3603

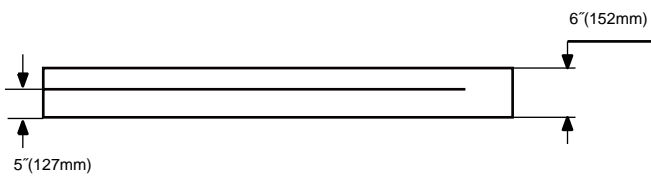
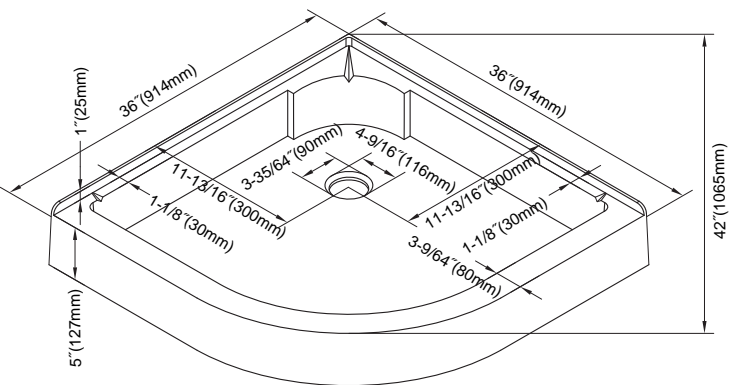

BS-RD3802

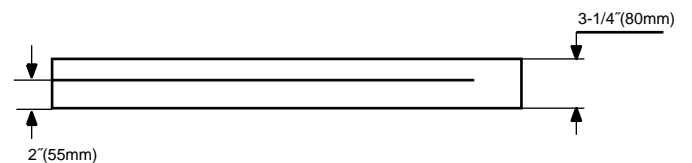
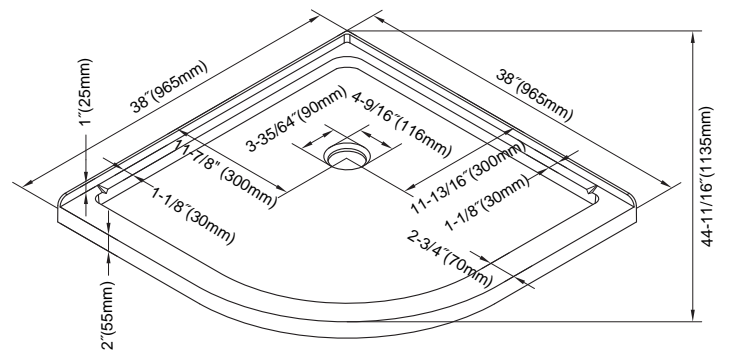

BS-NA3801

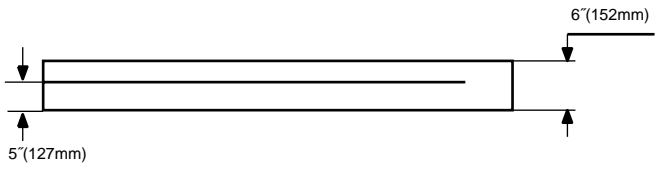
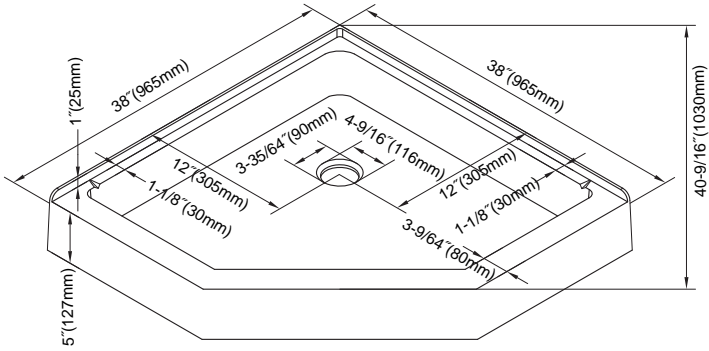

BS-NA3803

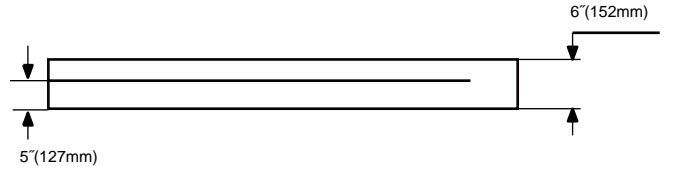
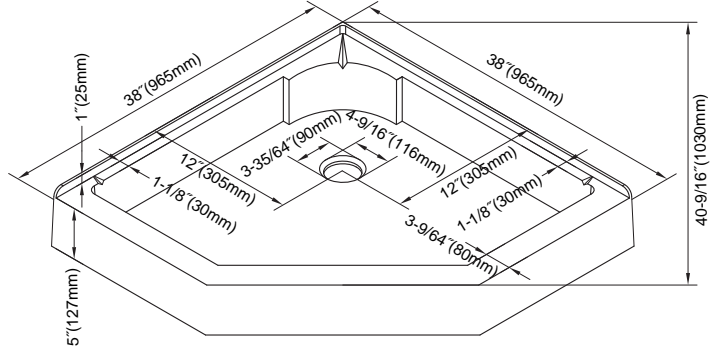

BS-RD4001

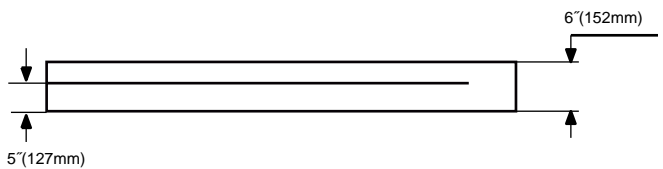
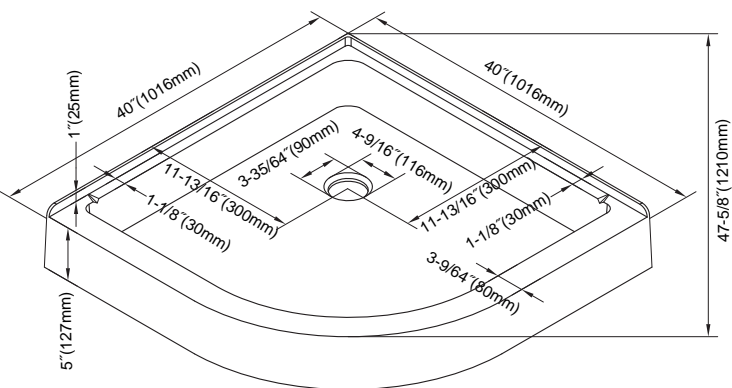

BS-RD4003

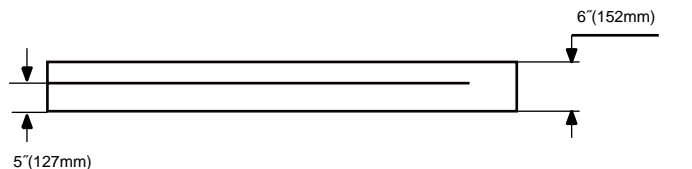
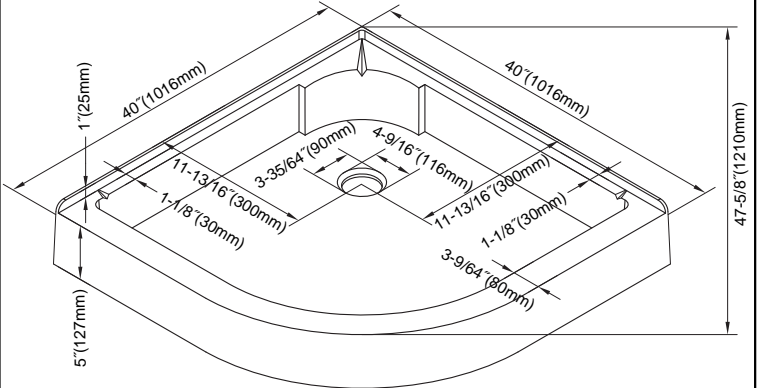

BS-RT3442L (2LIPS)

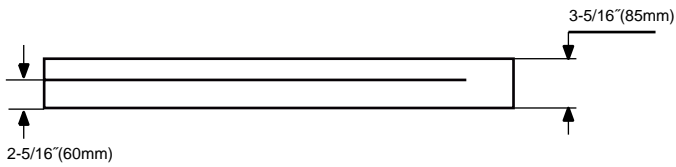
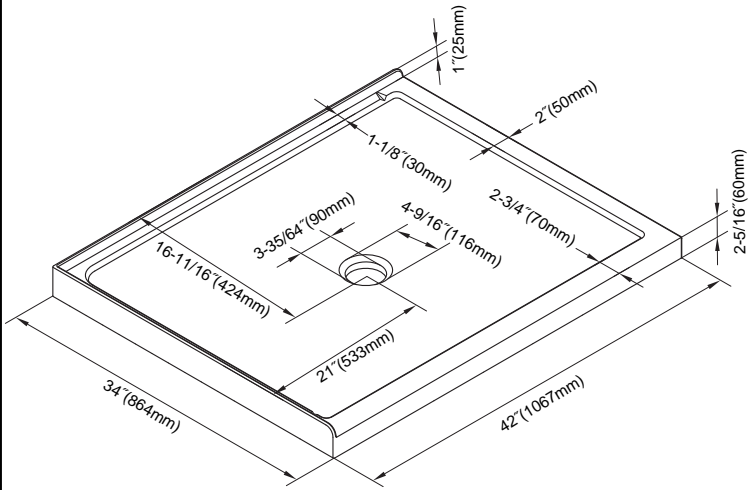

BS-RT3442R (2LIPS)

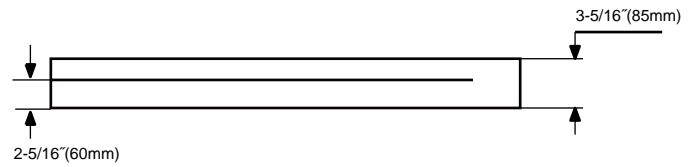
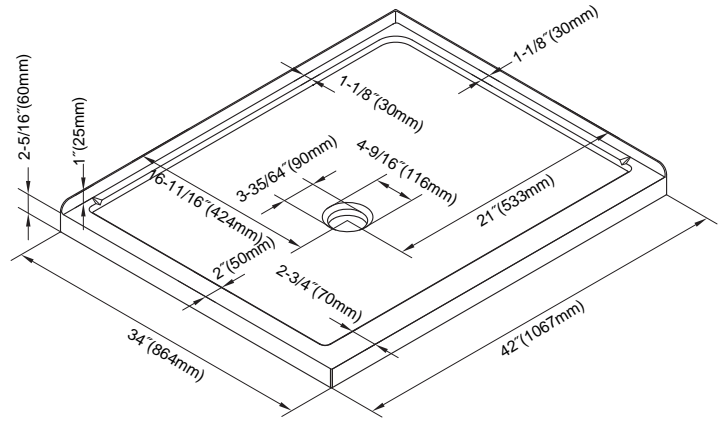

BS-RT3434

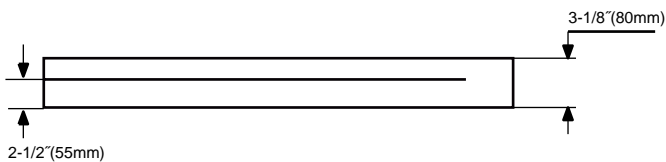
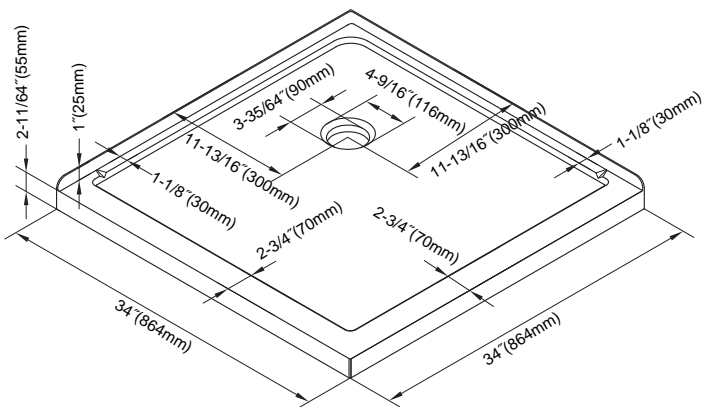

BS-RT3648-W3

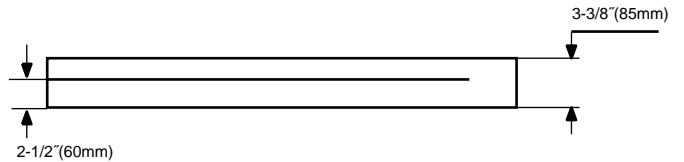
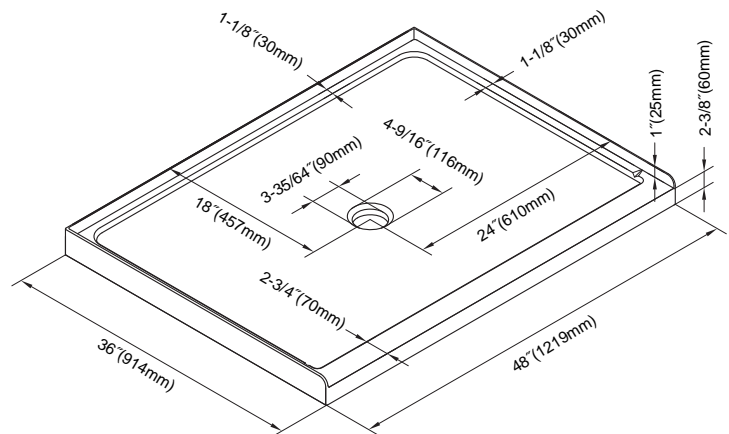

BS-RT3636W3

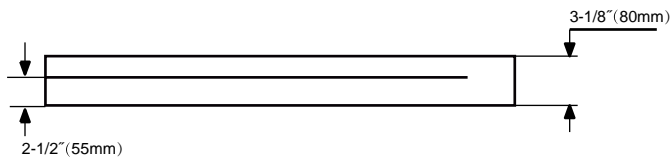
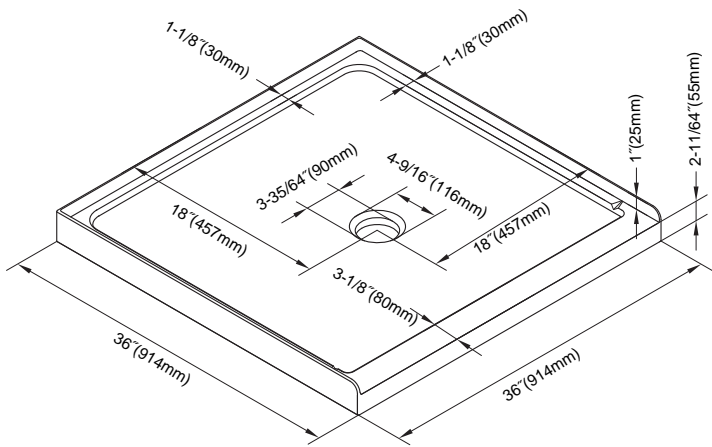

BS-RT3636W2

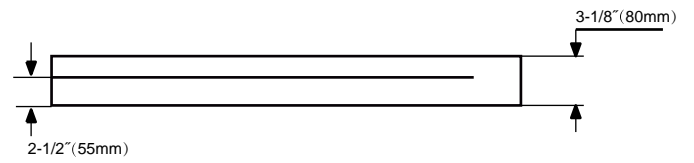
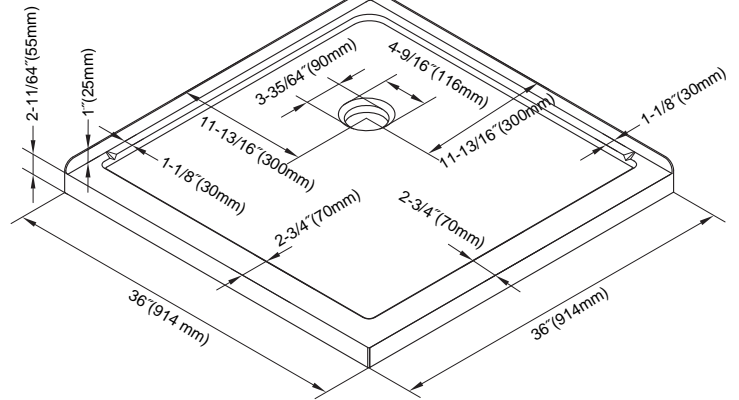

BS-RT3648L (2LIPS)

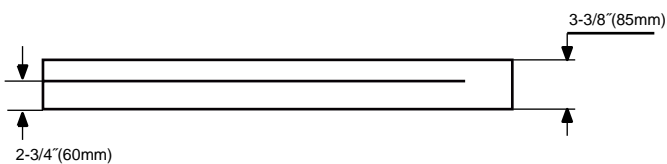
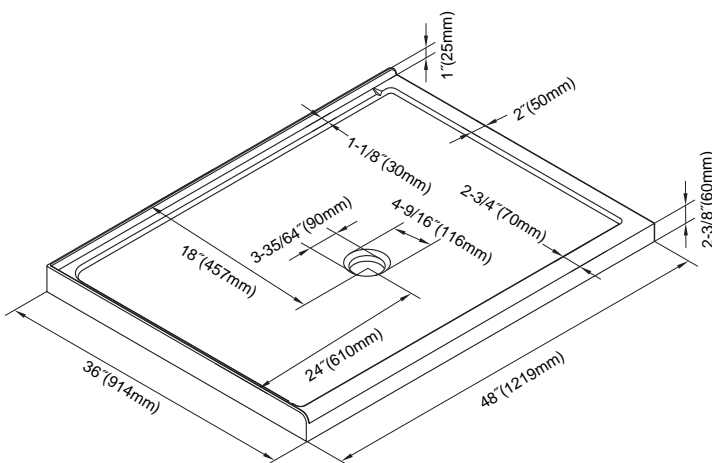

BS-RT3648R (2LIPS)

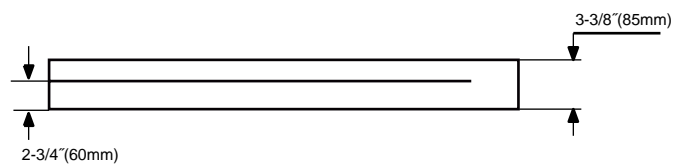
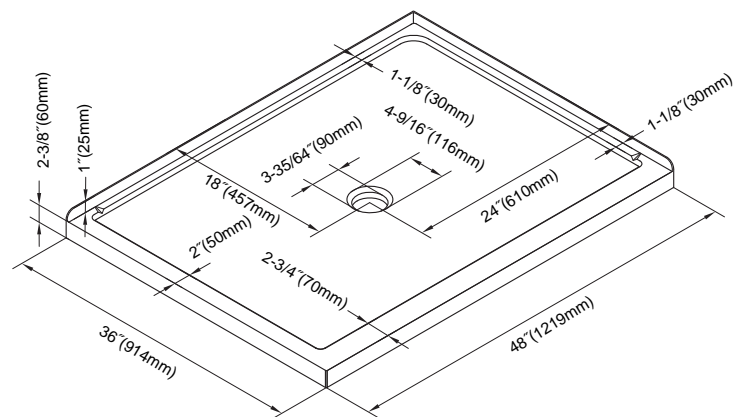

BS-RT503260L (W/3LIPS)

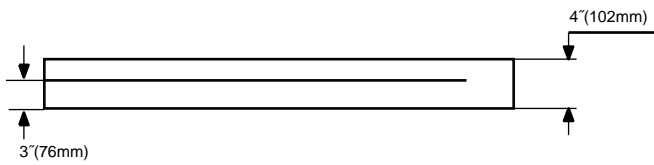
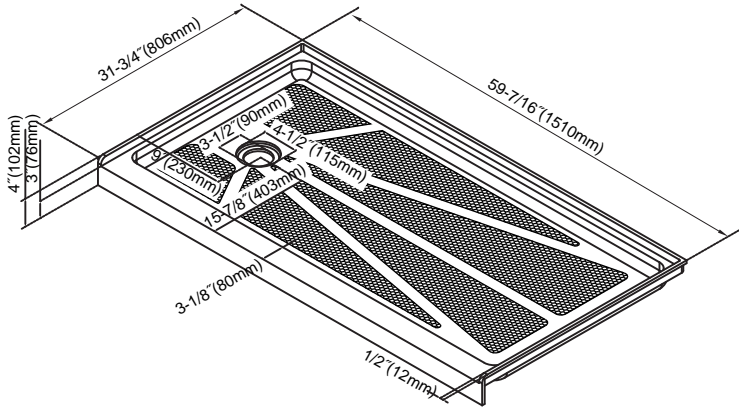

BS-RT503260R (W/3LIPS)

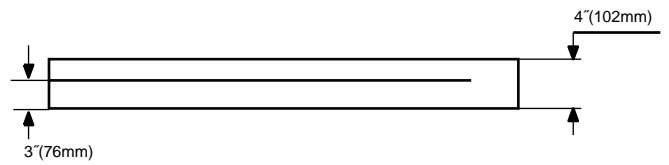
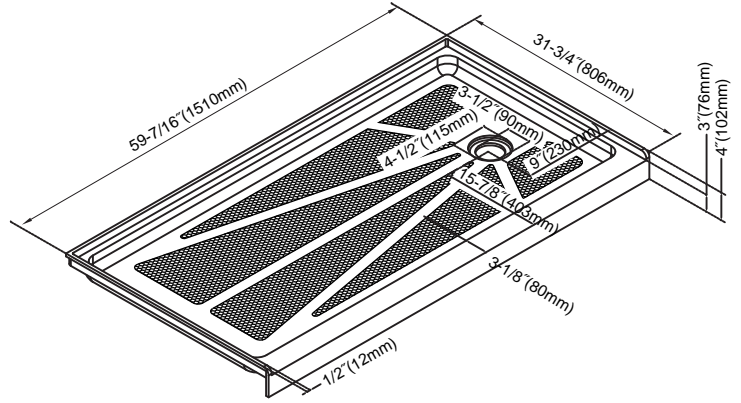

BS-RT503236R

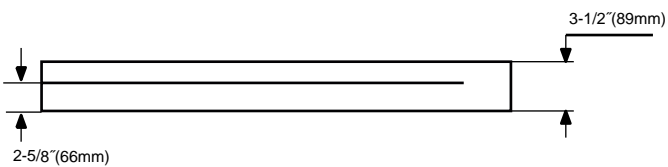
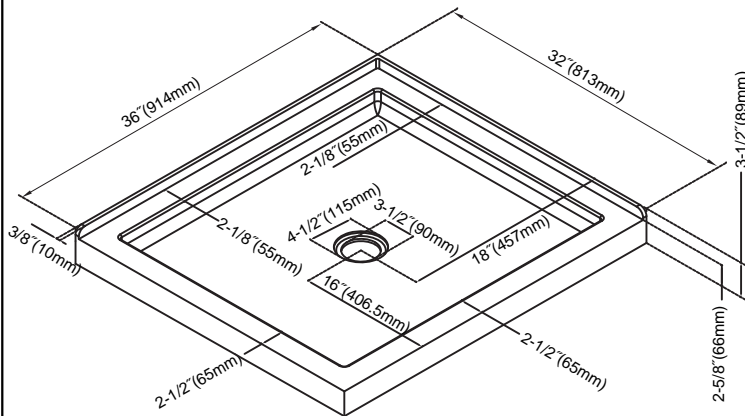

BS-RT503236L

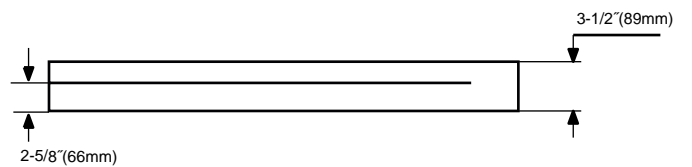
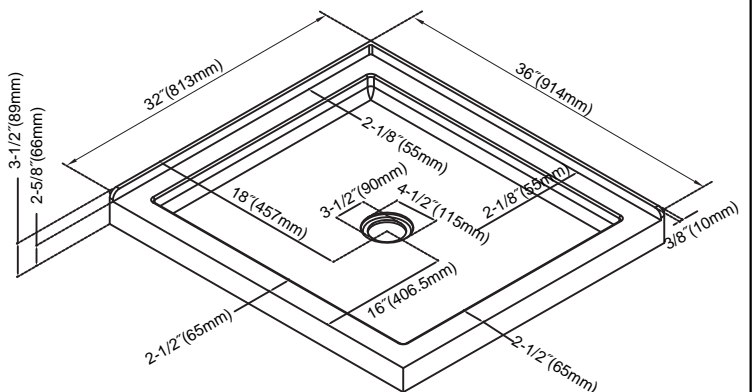

BS-RT503248R

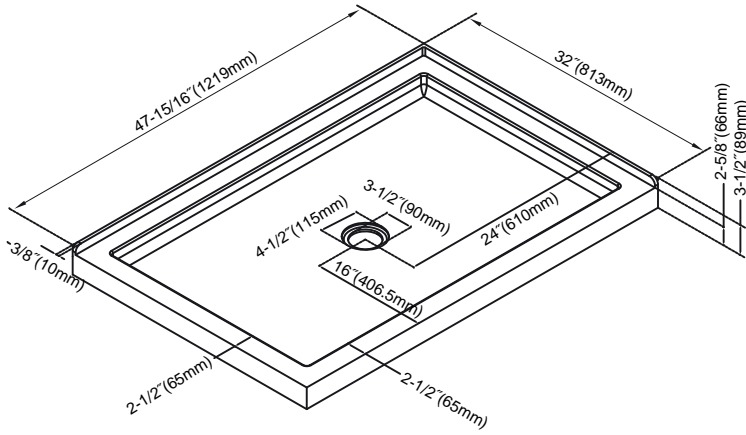

BS-RT503248L

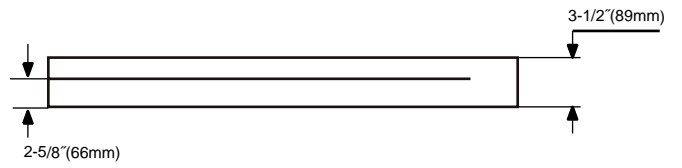
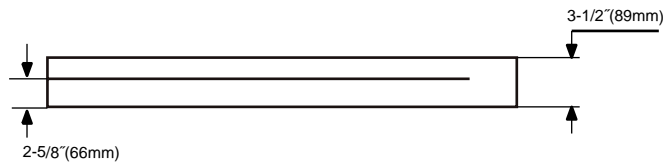
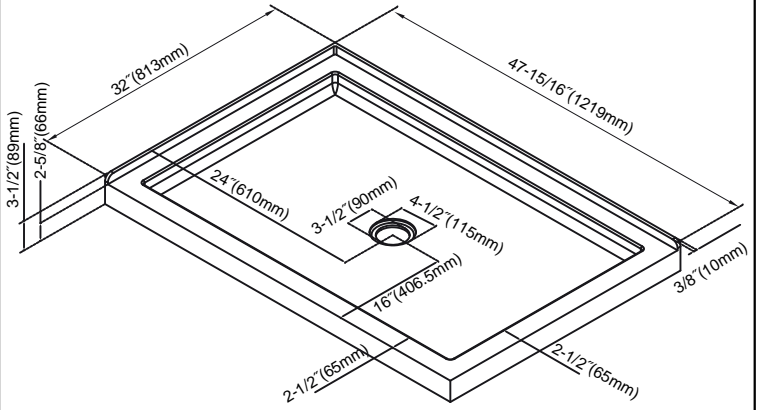

BS-RT533660R

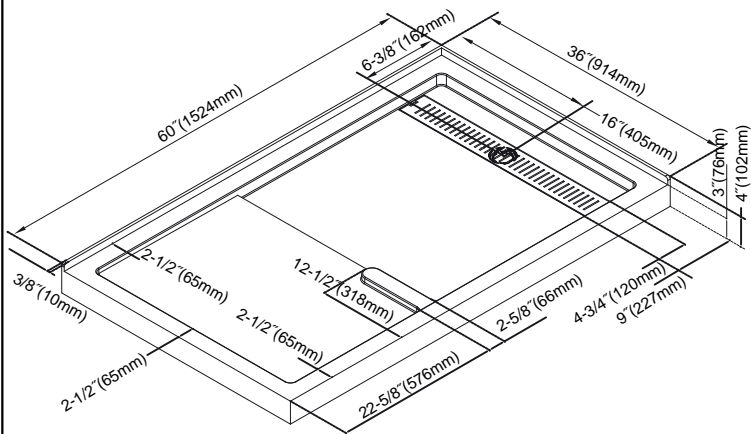

BS-RT533660L

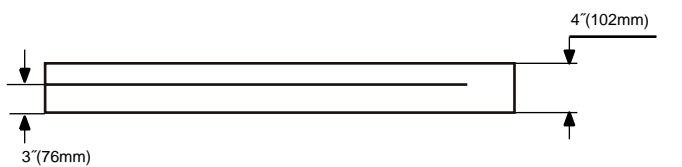
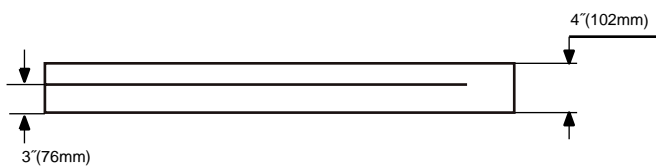
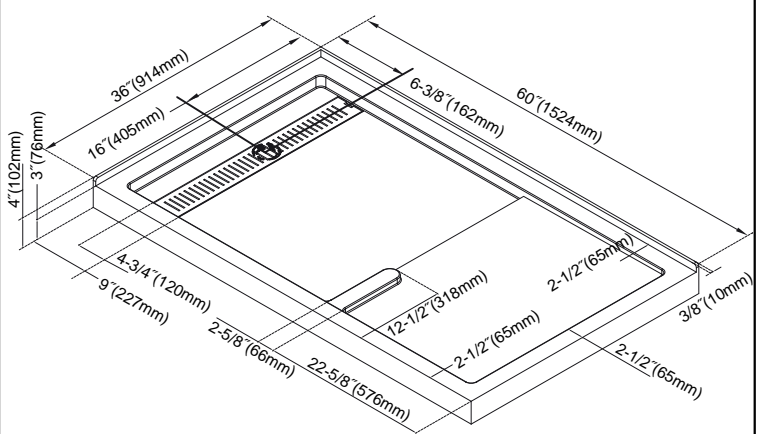

BS-RT513260R

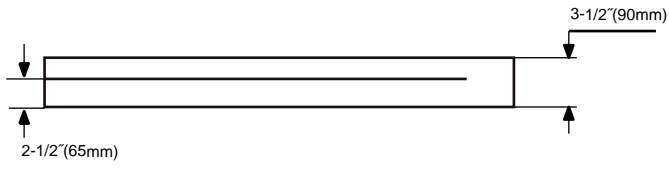
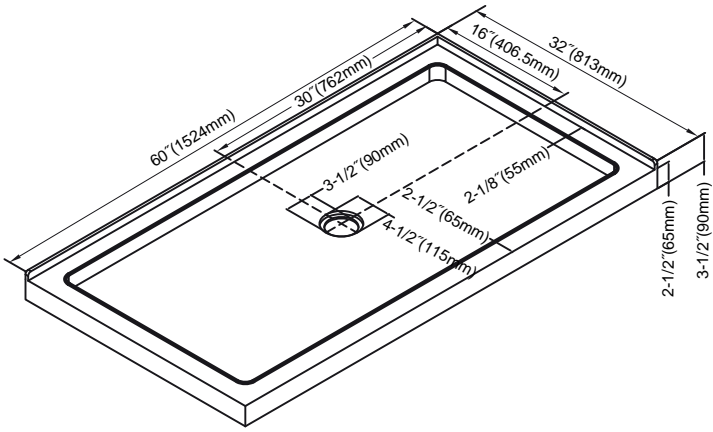

BS-RT513260L

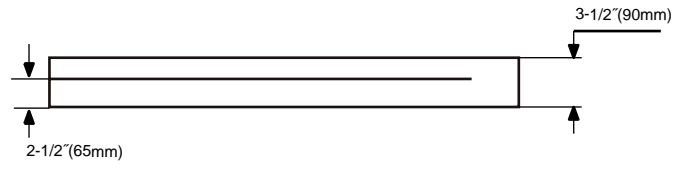
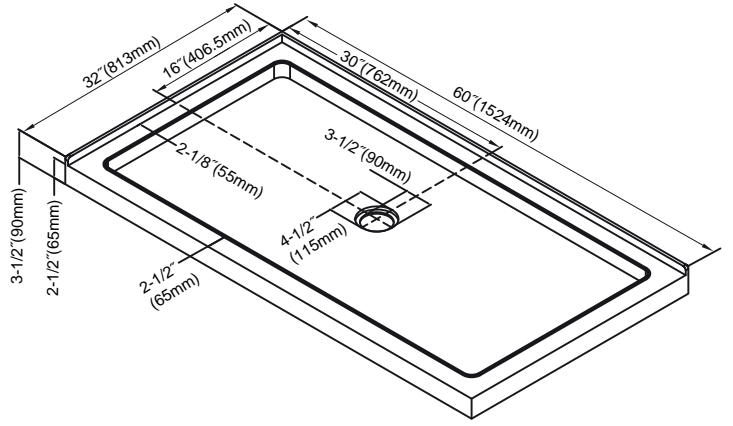

BS-RT513260W3

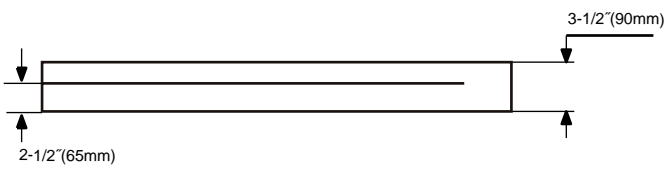
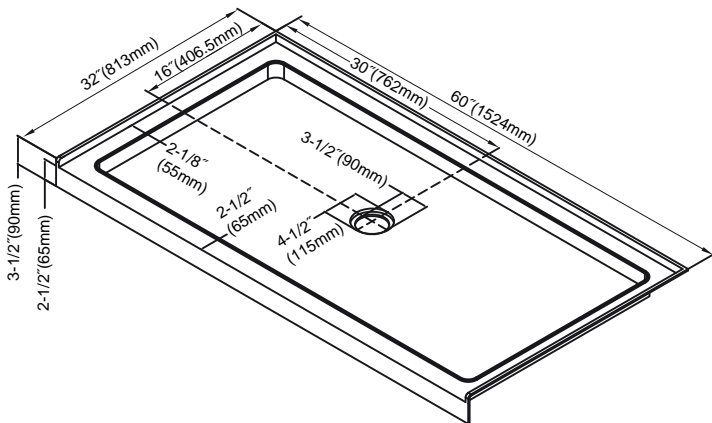

BS-RT3660W3

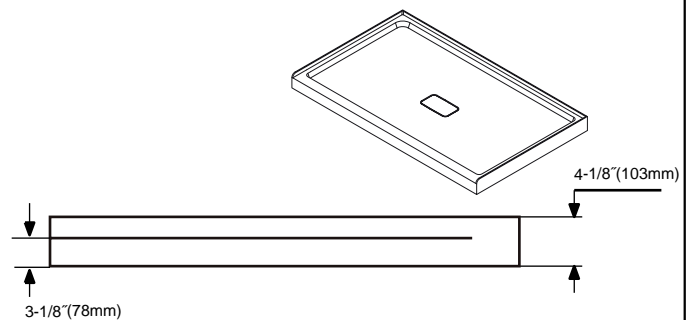
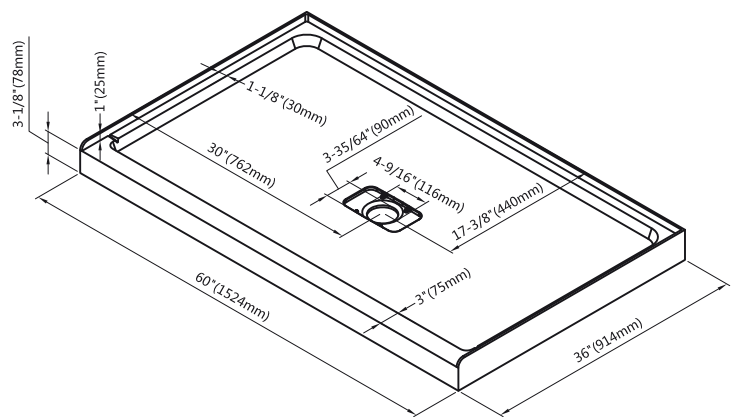

BS-RT3660L

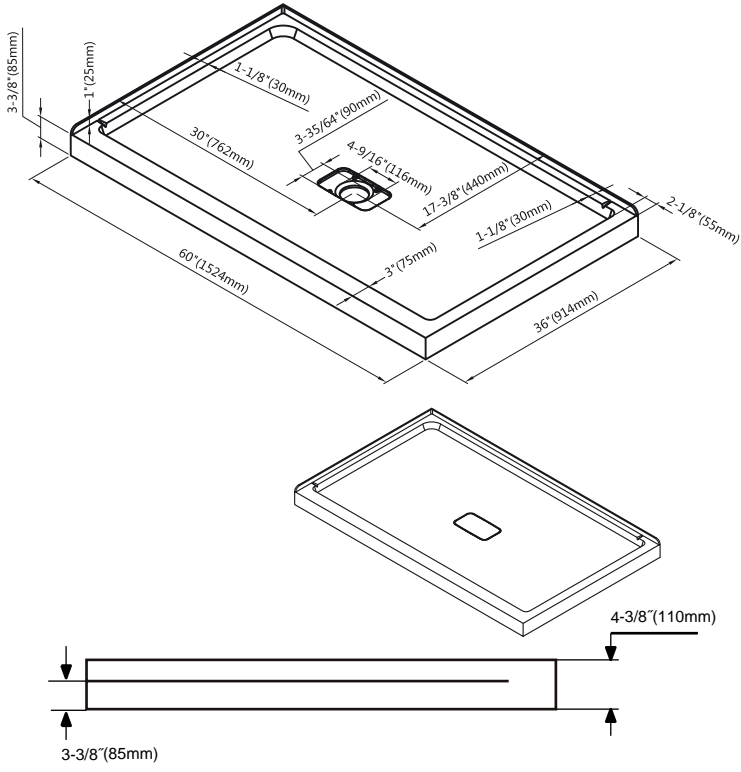

BS-RT3660R

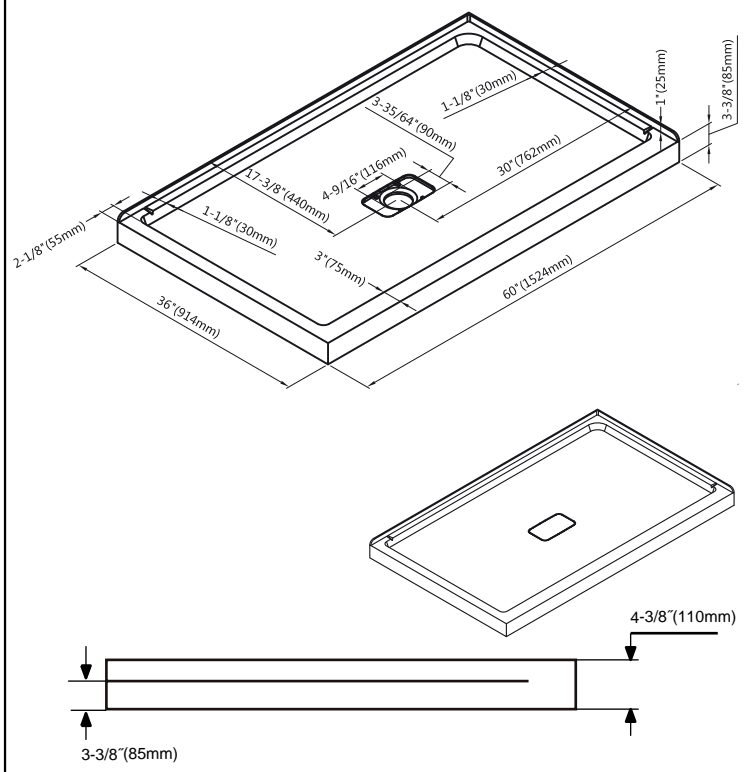

PROTECTION BASE / BASE PROTECTION

A

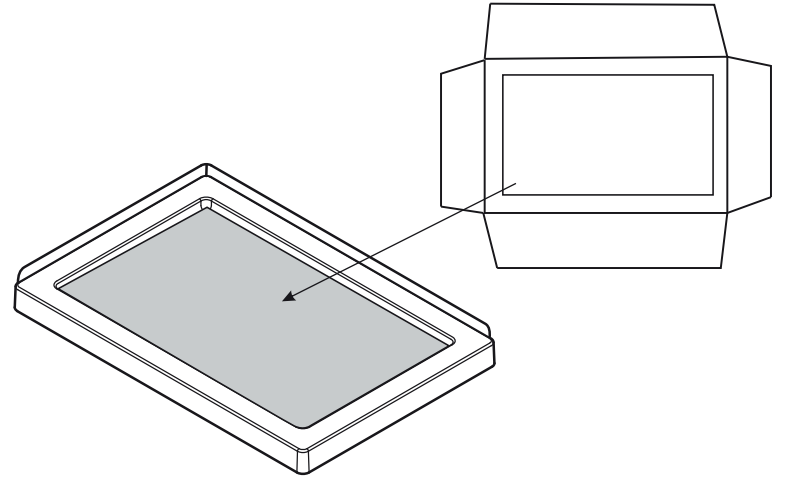
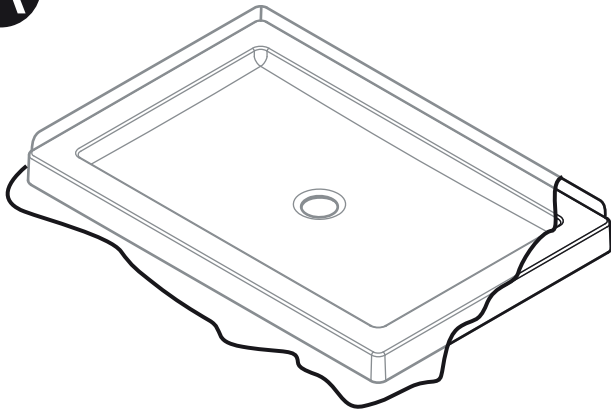

Enlever la pellicule de plastique protectrice
Remove protective plastic film if there have a film



Si vous faites l'installation d'une modèle en coin, svp suivre les instructions de la section 2.
If you are proceeding with the installation of a corner model, please follow instructions in section 2.

Si vous faites l'installation d'un modèle rectangulaire, svp suivre les instructions de la section 3.
If you are proceeding with the installation of a rectangular model, please follow instructions in section 3

PRÉPARATION/PREPARATION ②

B

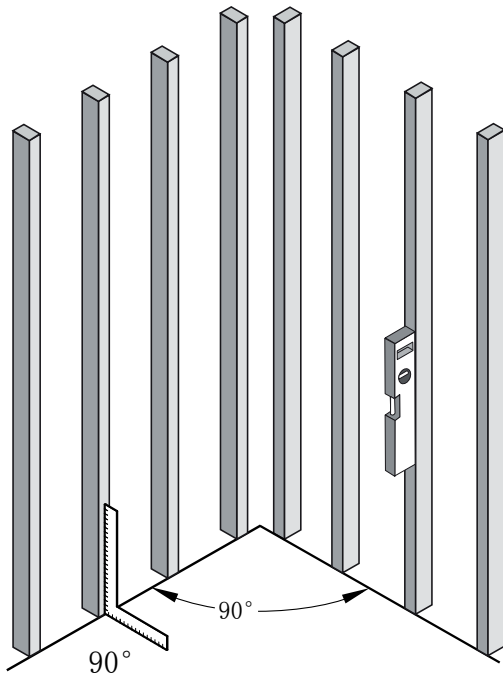

C

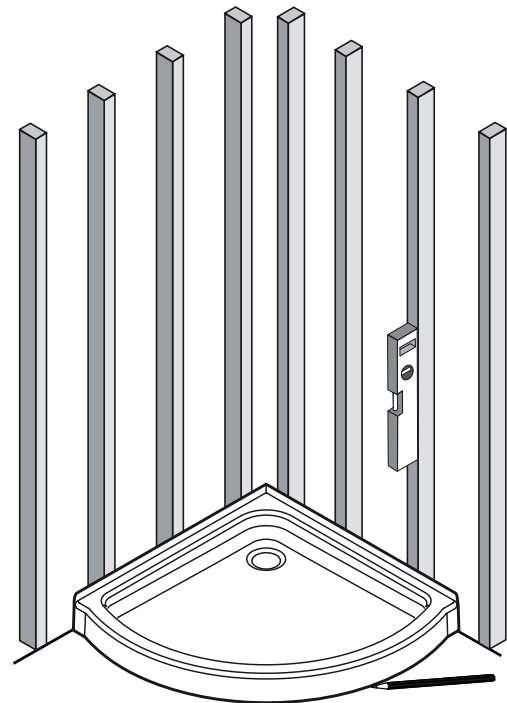

 ATTENTION !

Les murs de votre salle de bain doivent être de niveau pour une installation adéquate.

 WARNING !

Walls in your bathroom must be leveled for an adequate installation.

L'image est à titre de référence seulement.
La forme peut être carrée, rectangulaire ou néo-angle.

The image is for reference only.
The shape can be square, rectangular or neo-angle.

D

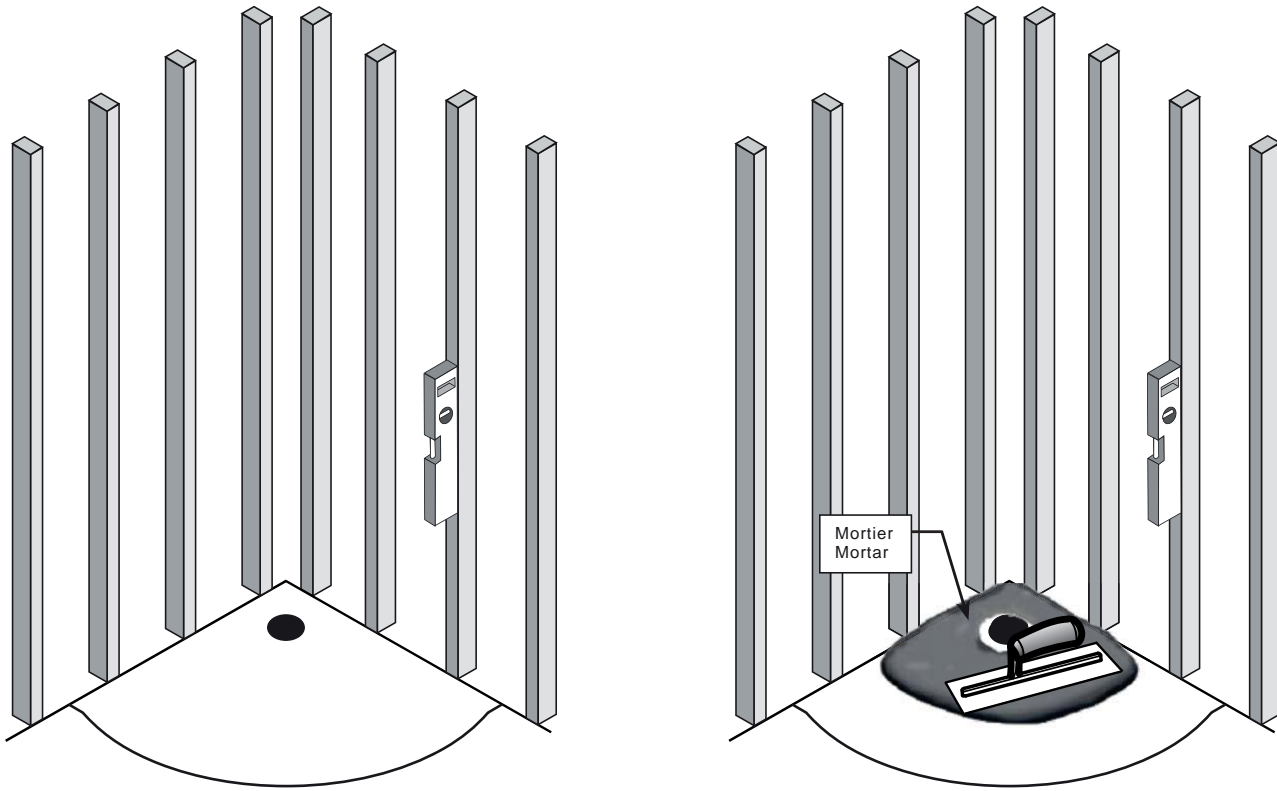

INSTALLATION BASE / BASE INSTALLATION

E

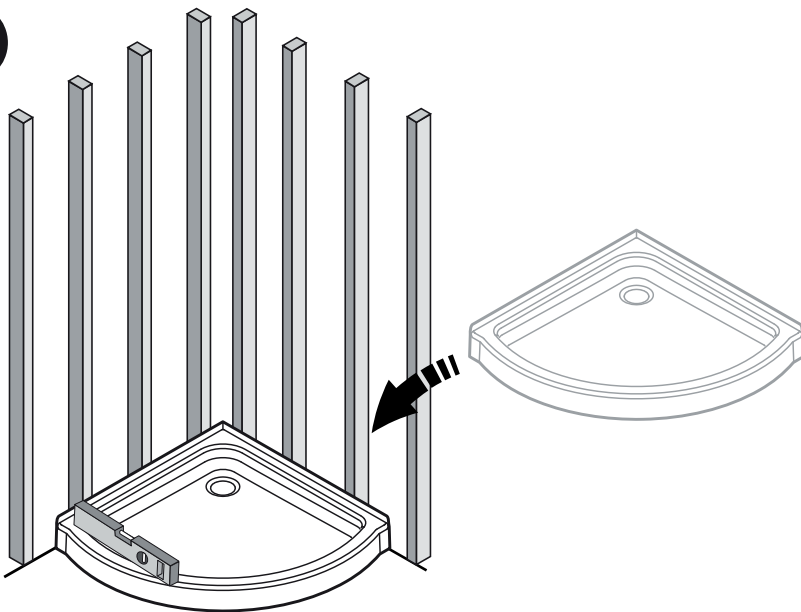

F

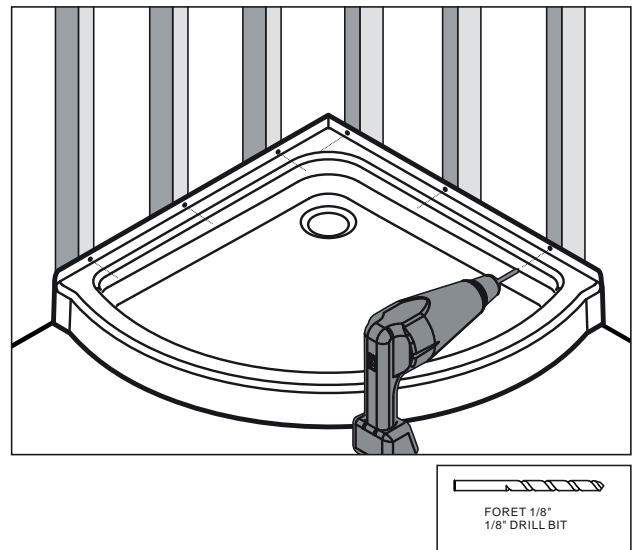

G

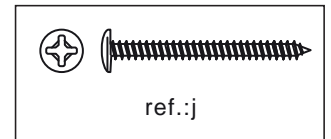
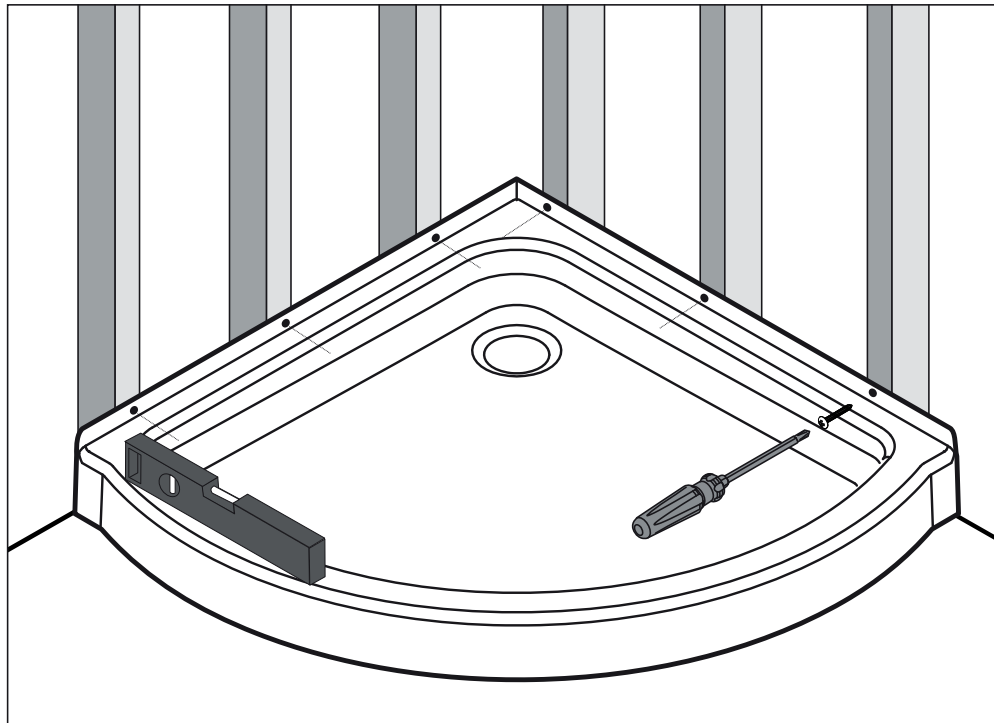

H

20~30mm

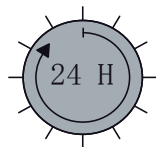
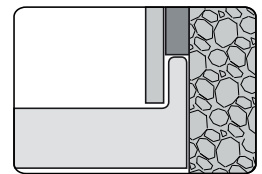

ATTENTION !

Attendre 24h avant d'installer votre porte de douche, afin de permettre au mortier et à la finition de sécher complètement.

WARNING !

Wait 24h before proceeding with the installation of the shower door. This will ensure that the finish and mortar is dry.

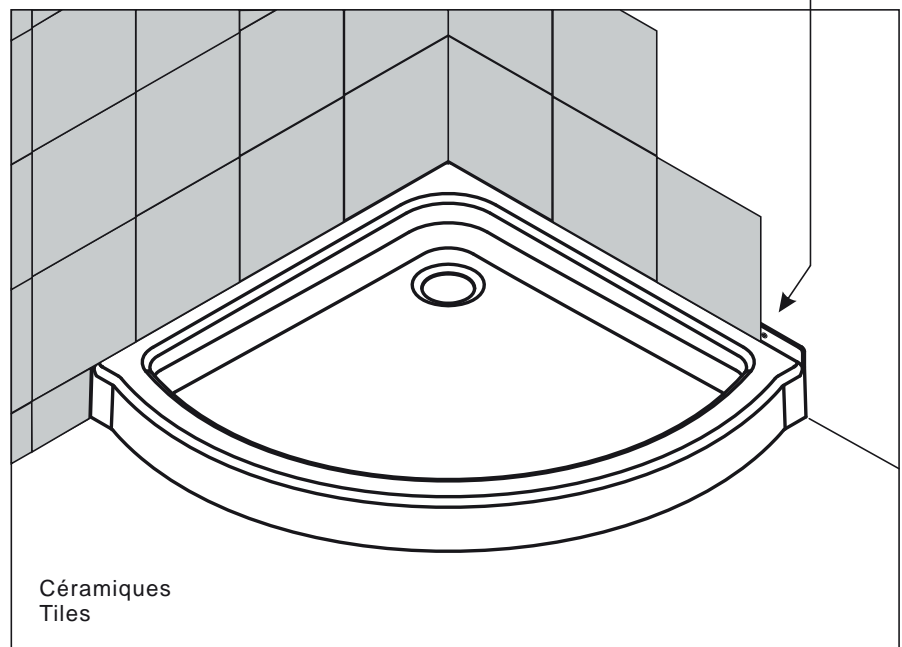

Céramiques
Tiles

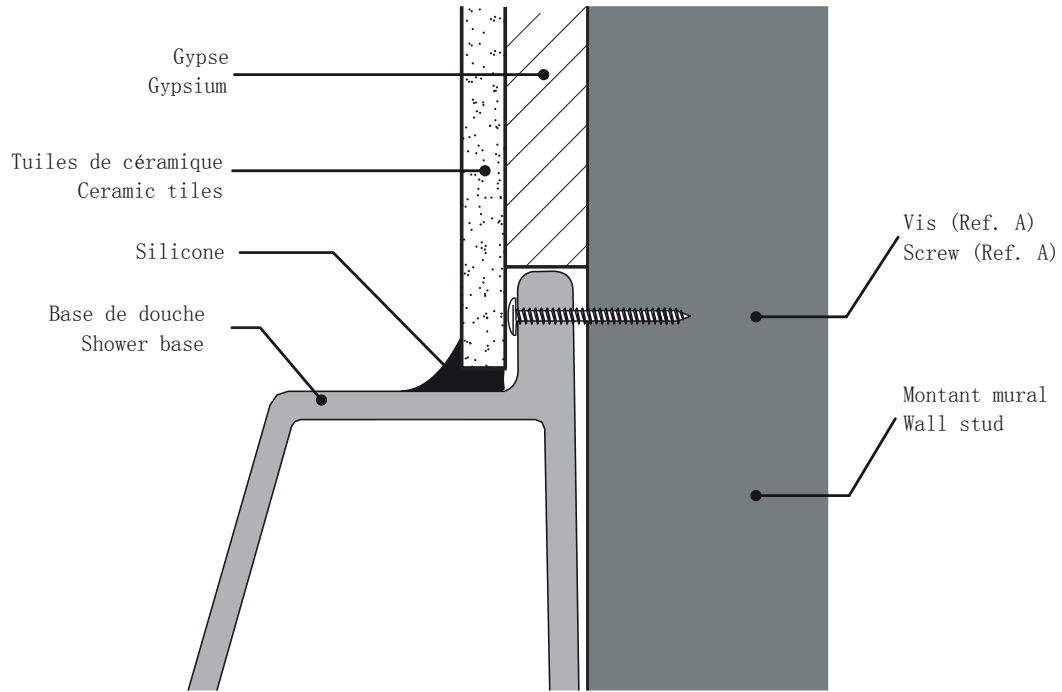

VUE SECTIONNELLE / SIDE SECTION VIEW

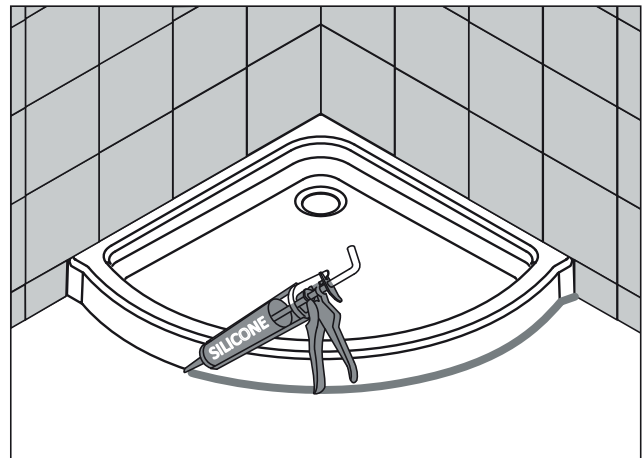
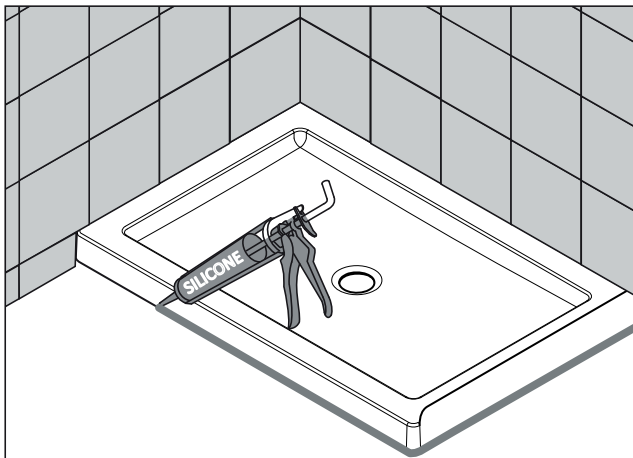
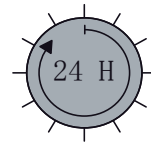

INSTALLATION BASE / BASE INSTALLATION

A 01

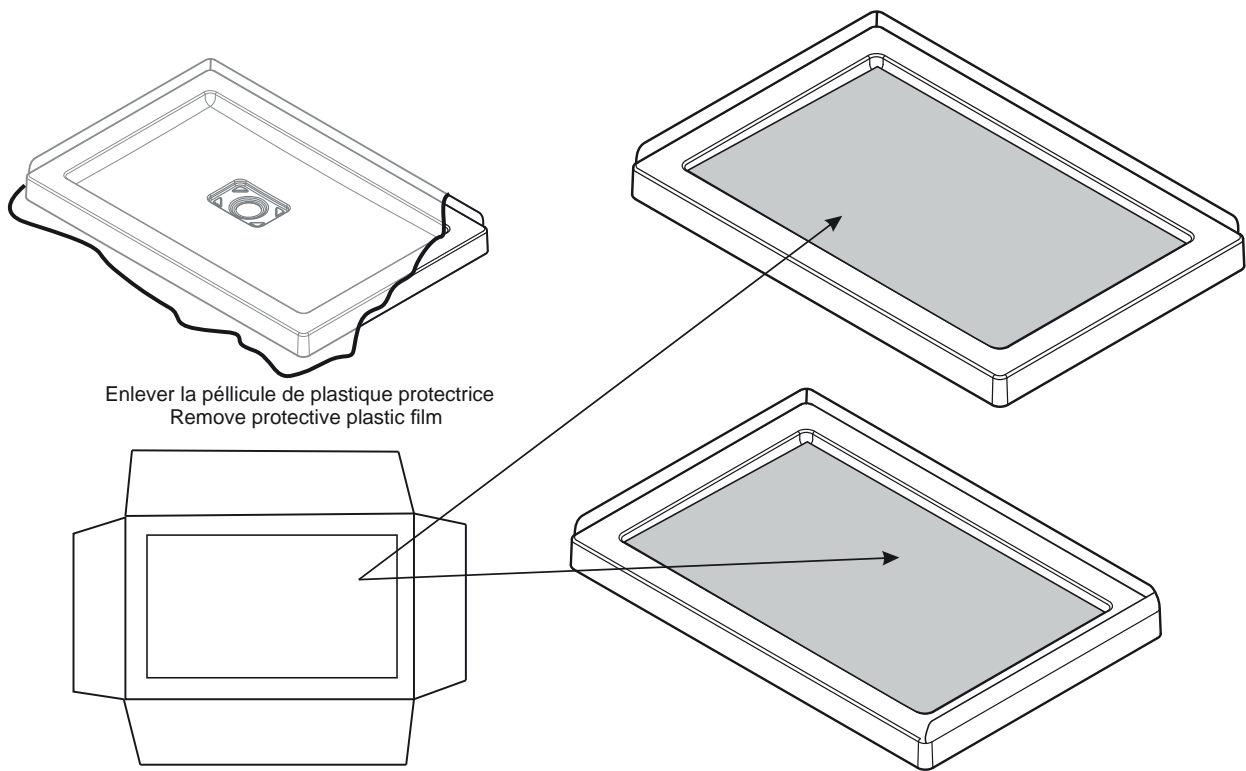

SUITE / CONTINUED

A 02

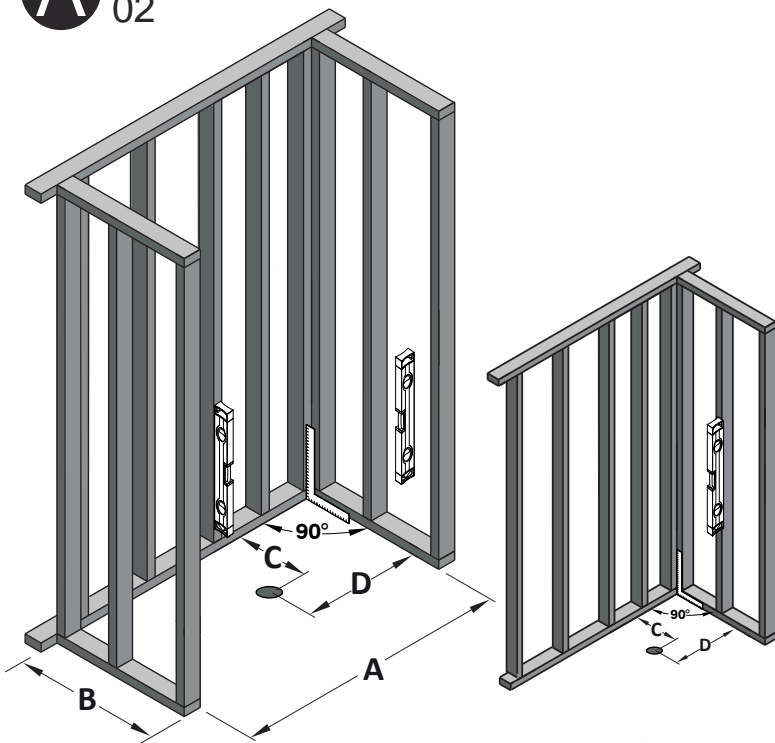

A 03

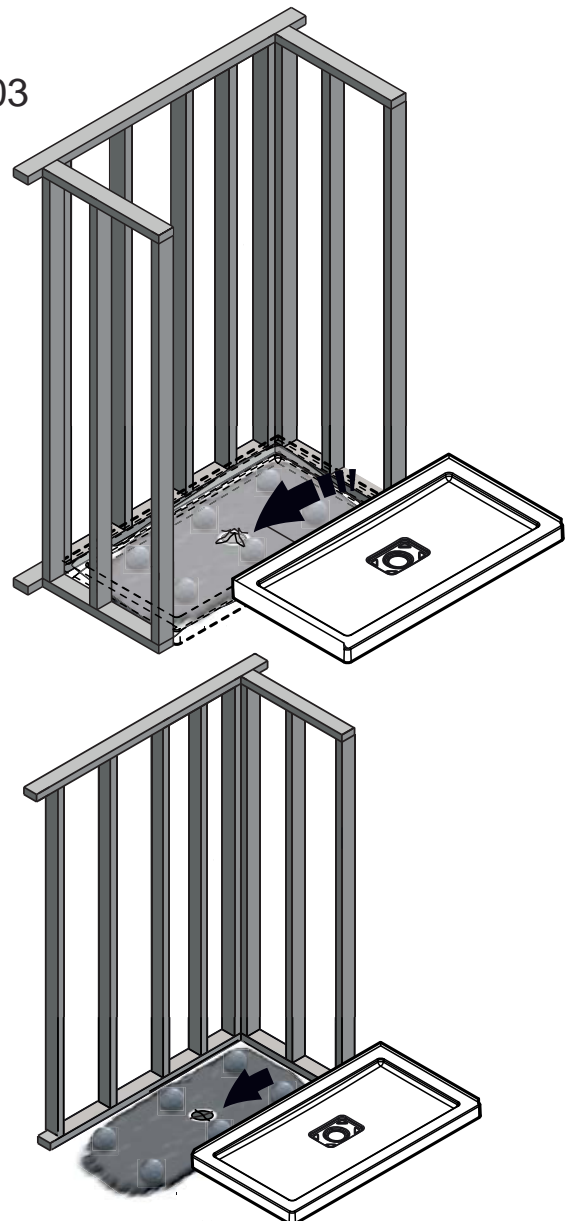

SUITE / CONTINUED

A 04

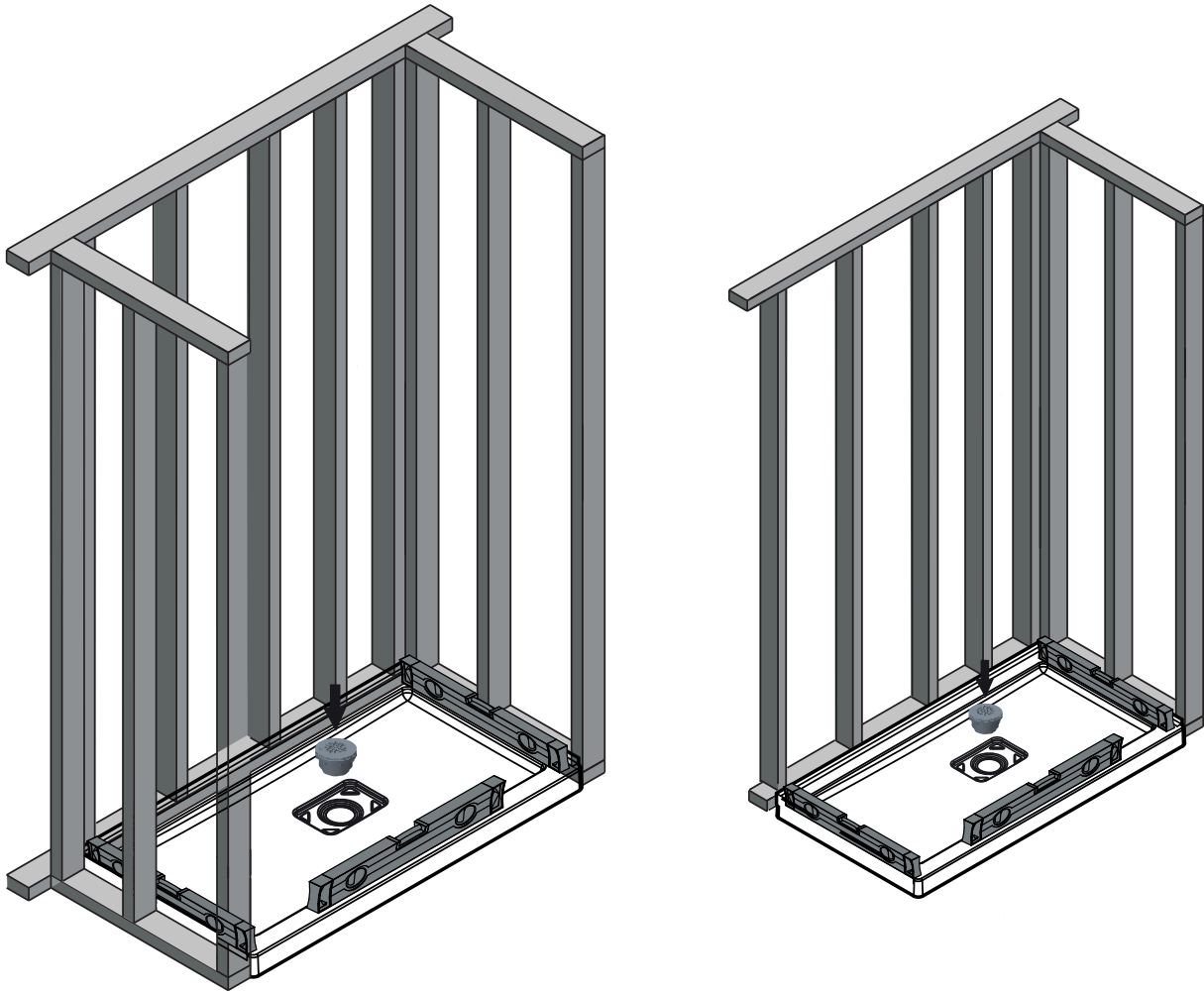

SUITE / CONTINUED

A 05

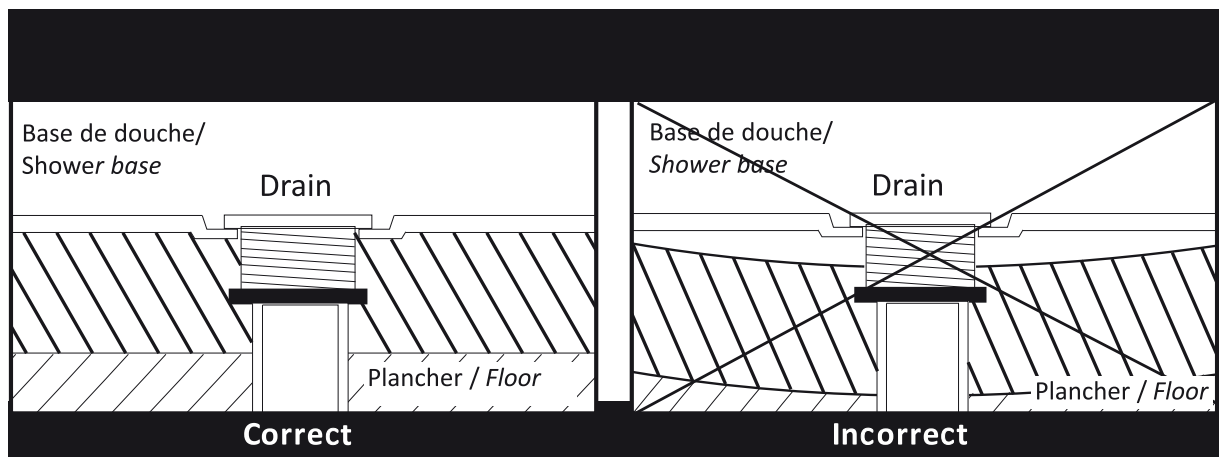
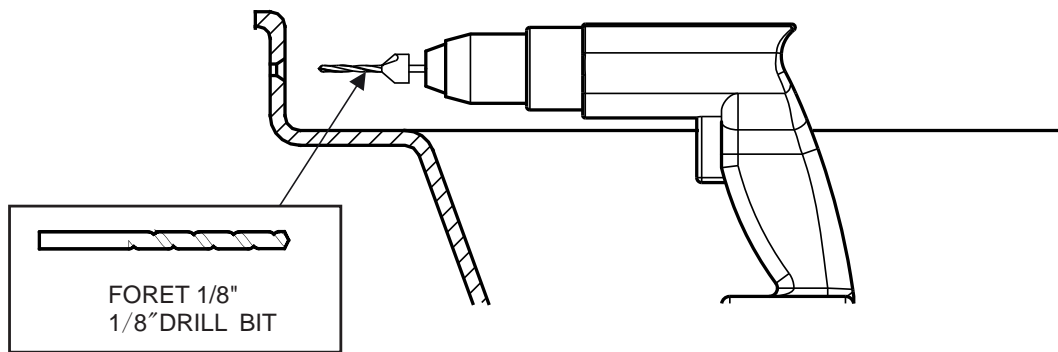

SUITE / CONTINUED

A 06

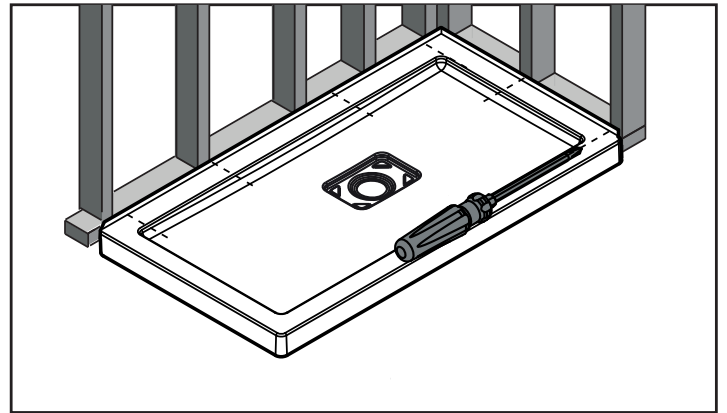
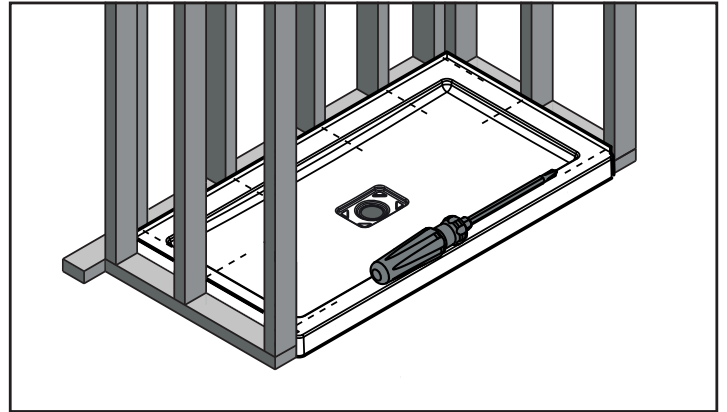
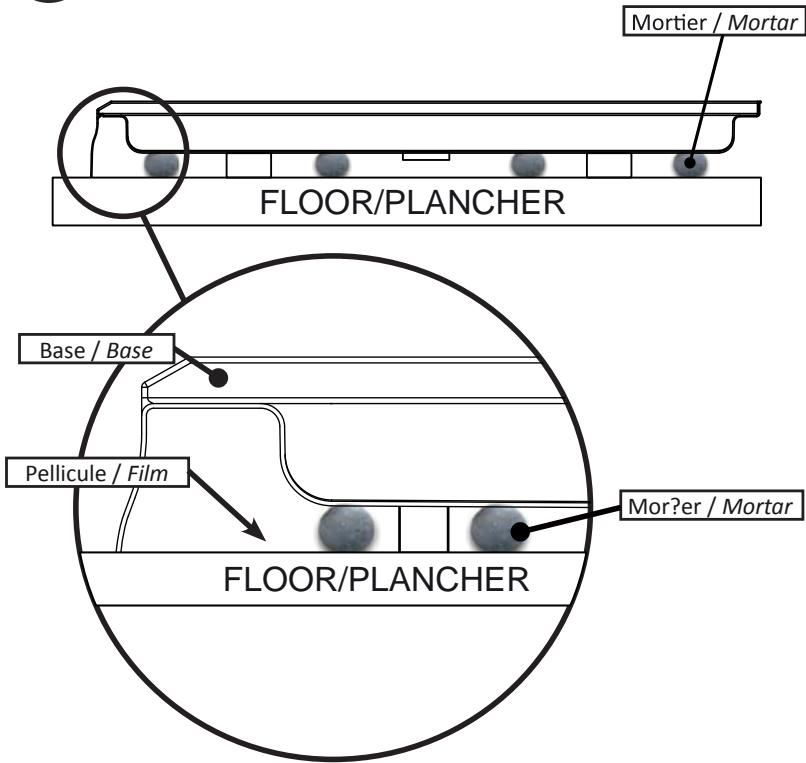

SUITE / CONTINUED

A 07

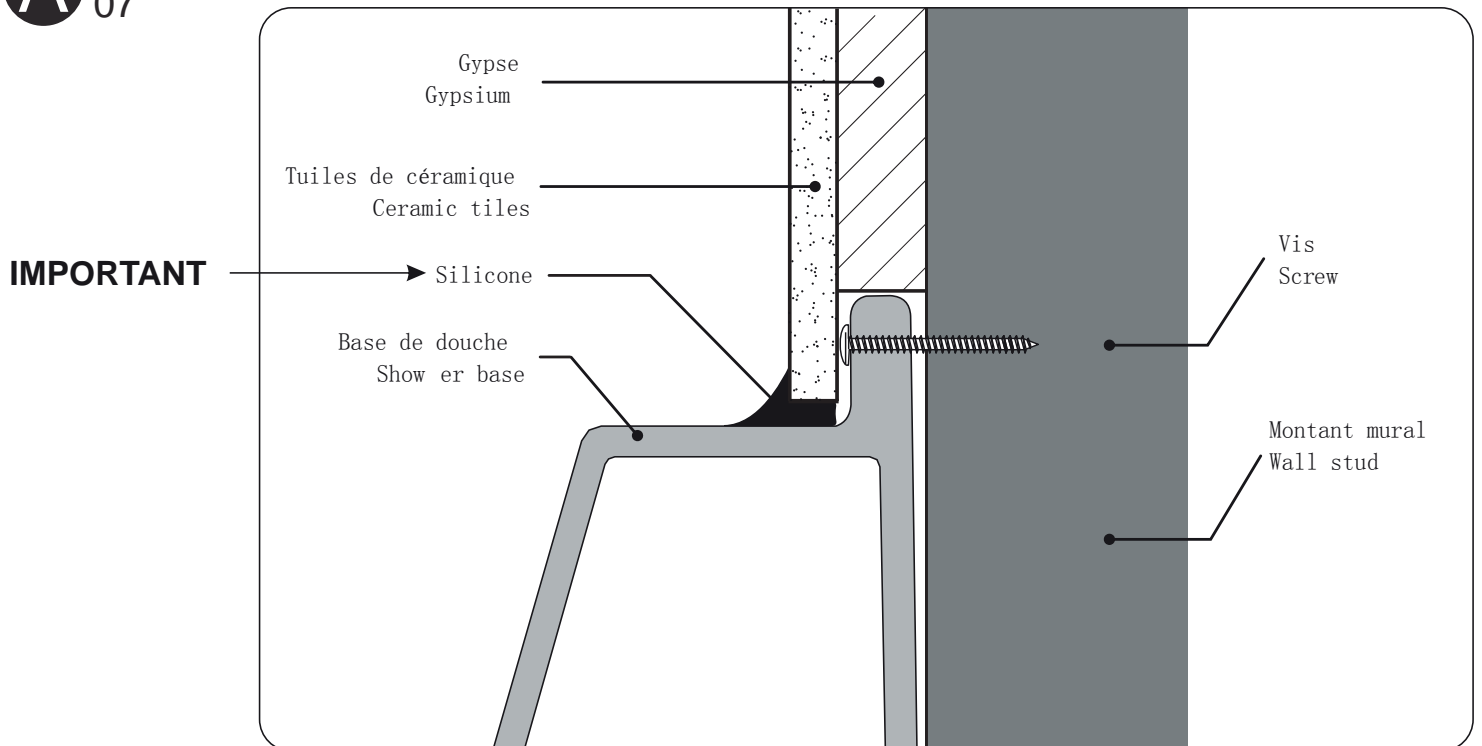

VUE SECTIONNELLE / SIDE SECTION VIEW

SUITE / CONTINUED

20~30mm

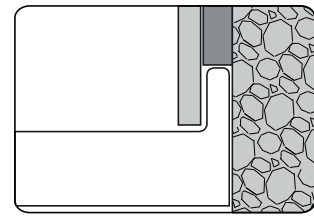

ATTENTION !

Attendre 24h avant d'installer votre porte de douche, afin de permettre au mortier et à la finition de sécher complètement.

WARNING !

Wait 24h before proceeding with the installation of the shower door. This will ensure that the finish and mortar is dry.

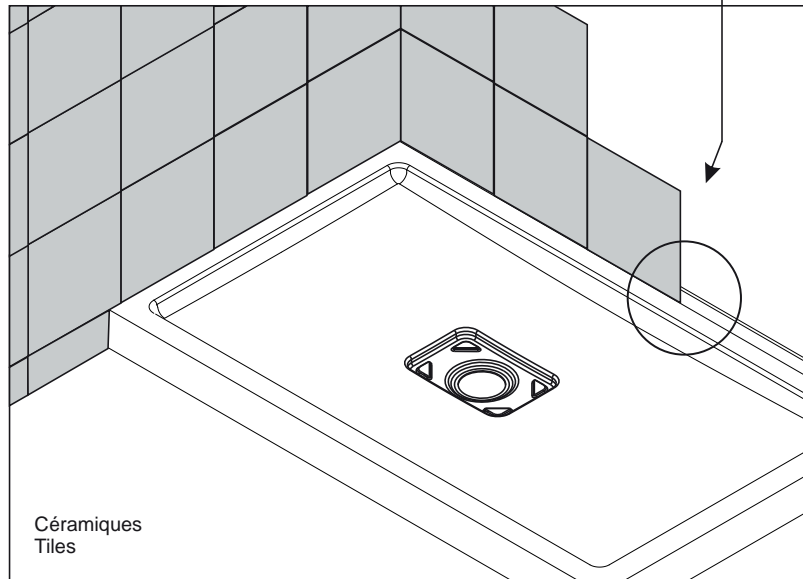

SUITE / CONTINUED

A 08

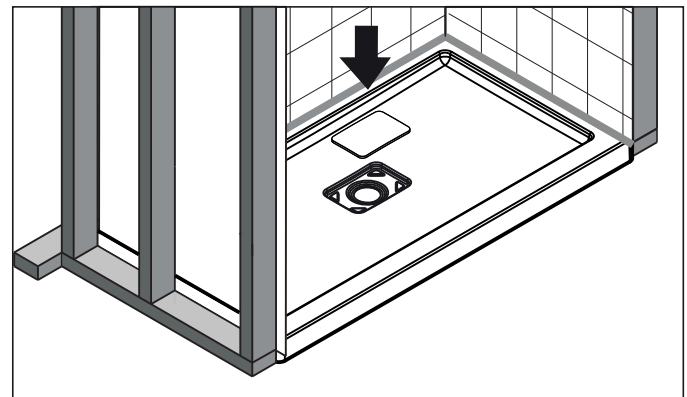
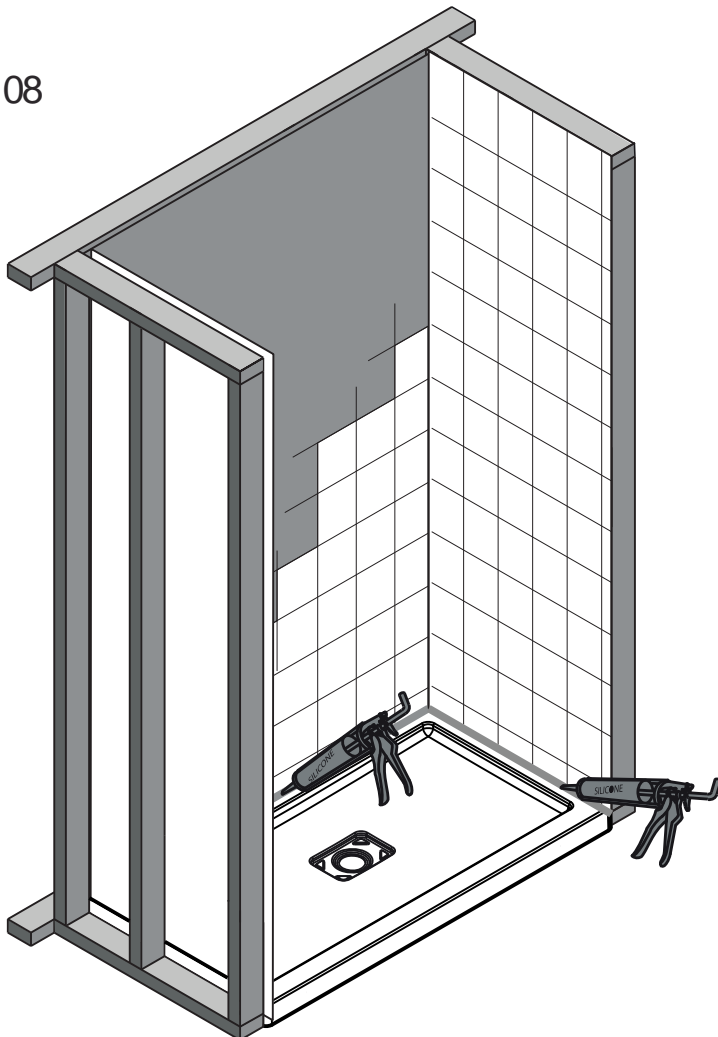
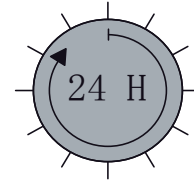

GARANTIE

Votre base de douche Bain Dépôt est garantie contre tout défauts de fabrication à partir de la date de la livraison. Cette garantie de un (1) an couvre la structure de fibre de verre (1 an) et la finition d'acrylique (1 an).

Cette garantie s'adresse seulement au propriétaire original. Elle couvre les pièces pour la première année. Cette garantie ne couvre pas les frais de déplacement, les frais d'installation ou de désinstallation ni les frais de transport.

Cette garantie ne couvre pas les dommages causés par la nature, la foudre, le feu, les brûlures, un mauvais usage, un usage abusif, la négligence, les bris résultant d'un choc ou d'une mauvaise manutention, l'utilisation de produits chimiques ou abrasifs ou l'usage d'eau incorrecte.

Cette garantie n'est valide que si les instructions d'installation ont été suivies et si l'installation a été complétée par des professionnels reconnus de l'industrie de la construction. Vous devez donc obtenir et conserver les directives et papiers d'installation en tout temps.

Cette garantie se limite, au choix du manufacturier, à la réparation ou au remplacement du produit et de ses systèmes ou de ses composantes. Aucune indemnité ne pourra être réclamée suite à la perte de jouissance de la vie, à la perte de revenu ou aux pertes causées par l'eau.

S'il y a des défauts de fabrication couverts par cette garantie, Bain Dépôt devra avoir eu l'occasion de vérifier le produit et de donner suite à la présente garantie sans quoi aucun frais ou responsabilité ne seront assumés par la compagnie.

Aucune promesse implicite ou explicite ne fait partie de cette garantie.

ENTRETIEN

Nettoyer la surface régulièrement à l'aide d'un détergent doux et de l'eau. Ne jamais utiliser de détergents abrasifs puissants ni de tampons de laine d'acier, d'acétone, de produits de nettoyage à sec ou de composés d'ammoniaque. Pour les taches de peinture, utilisez de la térébenthine ou un diluant à peinture. Pour les taches de composé à joint, utilisez une palette de plastique ou de bois recouverte d'un linge humide, évitez les lames de métal et les brosses métalliques. L'utilisation d'un nettoyant spécialement formulé pour nettoyer les finis en acrylique est recommandée. Si un tapis de caoutchouc est utilisé, il doit être enlevé immédiatement après chaque utilisation. L'utilisation non conforme d'un tel tapis causera des dommages au produit. Si les instructions d'entretien ne sont pas respecté, votre produit ne sera pas couvert par la garantie.

WARRANTY

Your Bath Depot shower base is guaranteed against any manufacturing defect from the date of delivery. This guarantee covers the fiberglass structure for a duration of one (1) year, the acrylic finish for one (1) year.

This guarantee applies to the original owner. It covers parts for the first year. This guarantee does not cover travel expenses or installation fees, nor does it cover desinstallation fees of transportation.

The present guarantee does not cover damages caused by act of god, lightning, fire, burns, abusive and wrongful use, carelessness, breakage due to improper handling. Damages resulting from the use of chemicals or abrasive products or improper water.

This guarantee is valid only if the installation directions have been followed and the installation has been carried out by professionals well-established within the construction industry. You must therefore obtain and save the installation instruction and any installation papers and information to that effect.

This guarantee is limited at the manufacturer's choice, to the repairs or replacement of the product of its systems and/or any of its components. There shall be no possibilities of claiming any indemnity following the loss of life, the loss of income or losses caused by water.

In the case of any manufacturing defect covered by this guarantee, Bath Depot shall have had prior opportunity to check the product and to follow up on the present guarantee, as otherwise no cost or responsibility shall be assumed by the company.

No other explicit or implied promise is considered as being part of the present guarantee.

MAINTENANCE

Clean your product regularly with a mild detergent and water. Always use a non-abrasive cleaner and never use steel wool, acetone, or any powerful dry cleaning products on the surfaces. For paint stains, use turpentine or a paint thinner, for joint compound stains, use a plastic or wood palette covered with a damp cloth. Do not use a metal blade or metal brush. The use of products formulated especially to clean acrylic finishes is highly recommended. If a rubber mat is used, it must be removed immediately after each use. The improper use of these instructions will cause damages and are not covered by the warranty.



PN-NA3801 Installation Instruction Sheet Manuel d'installation

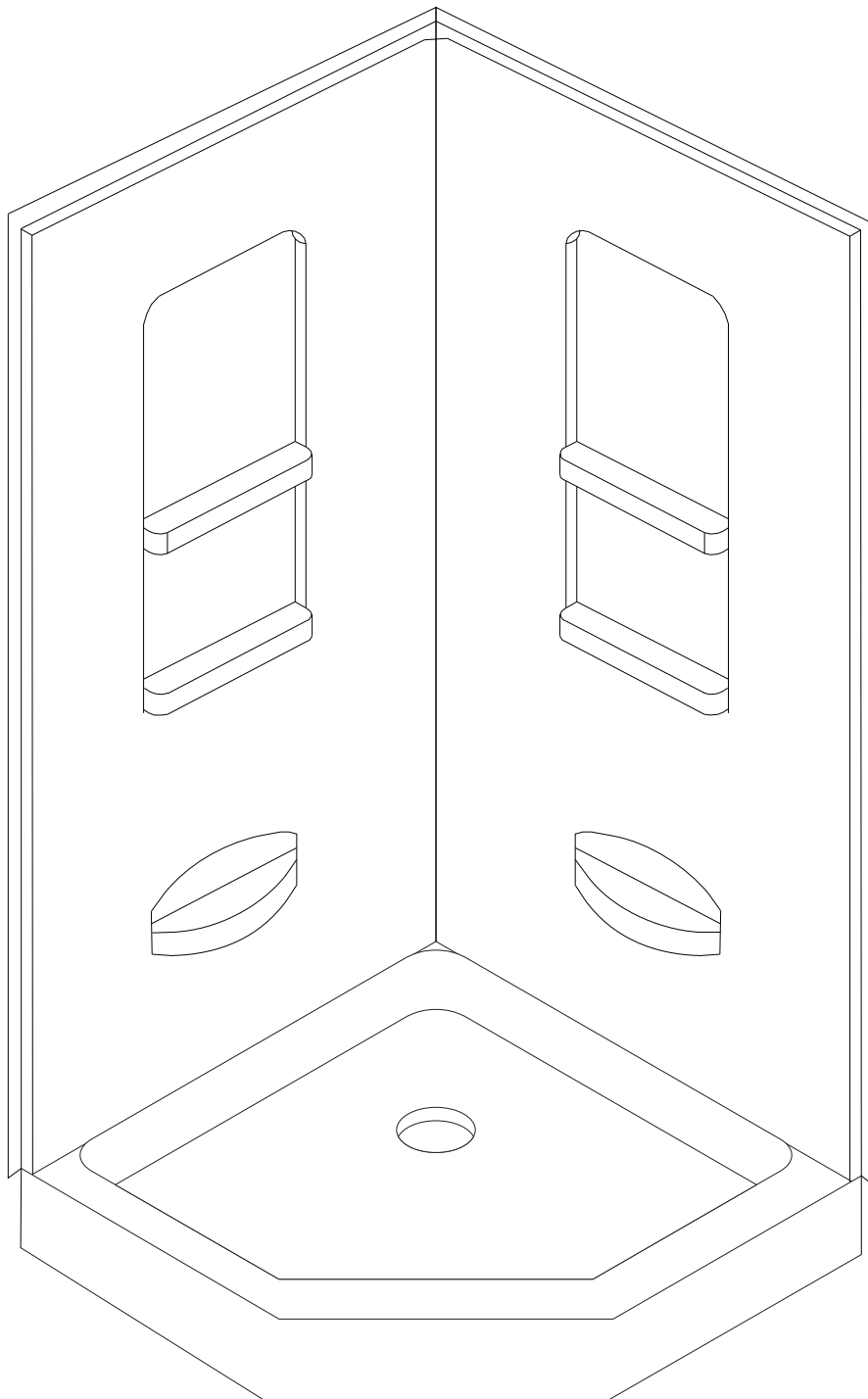



Instructions for installing shower cabin

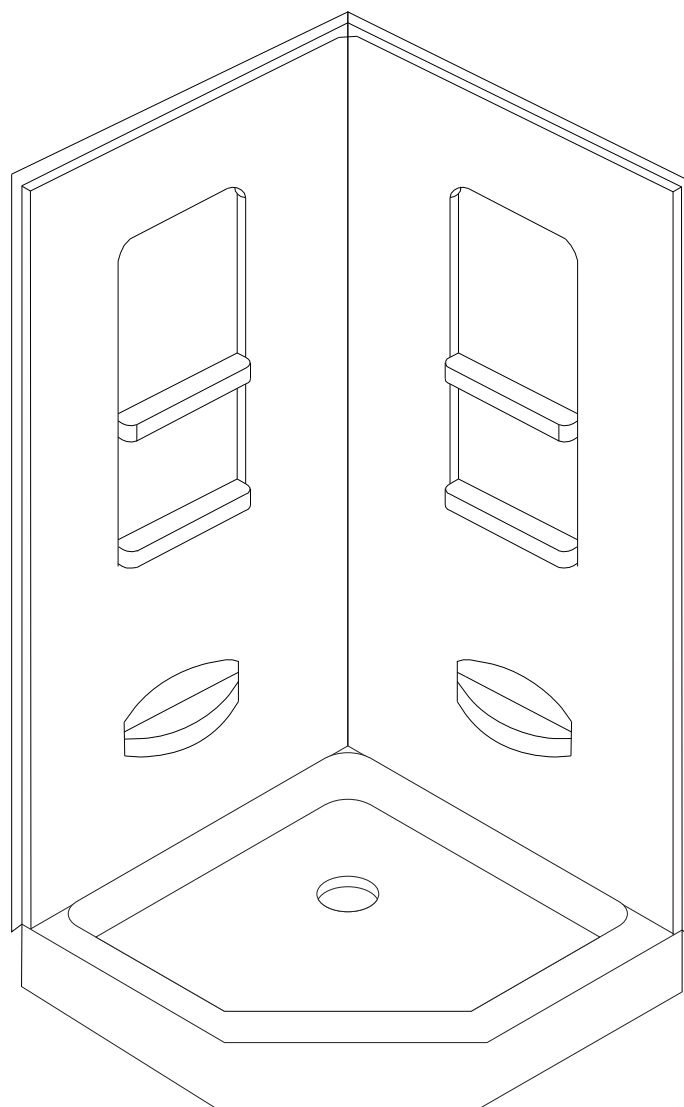

Intruction pour l'installation de la cabine de douche

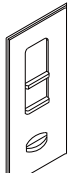
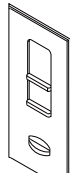
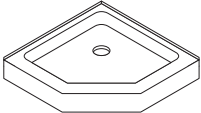
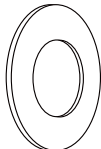

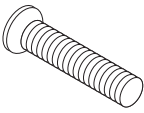
Elements:

A  1X	B  1X	C  1X	D  5X	E  5X	F  5X
--	--	--	--	--	--

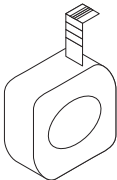
Tools:

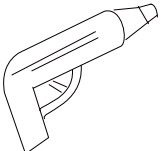
					
---	---	---	--	--	--

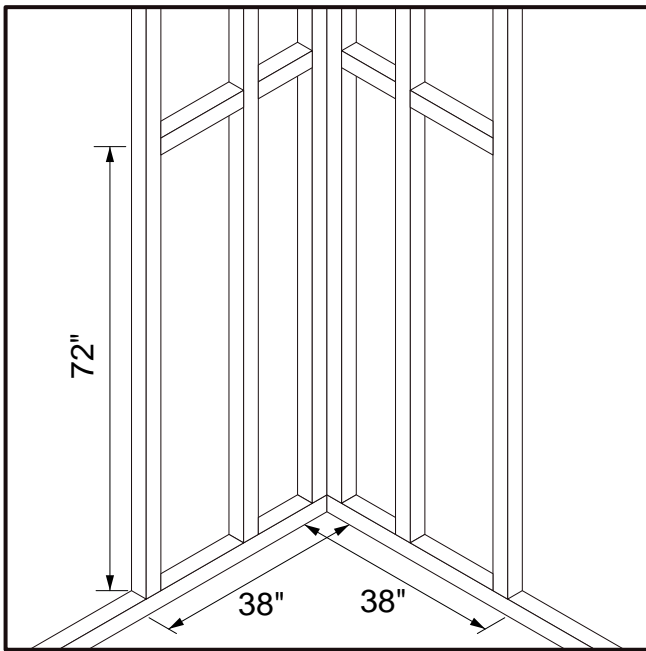

Step 1

A. Fix the the back board and bottom pot, with the 2"x 4" framework.

N.B. The size of the framework is for reference. The measurement should be done for the back board and bottom pot.n from

Étape 1

A. Fabriquer un cadre de fixation avec 2 bâtons en bois "2X4" pour fixer le bassin et le plaque du dos.

N.B.Référez au schéma pour la dimension de cadre afin d'assurer la précision. Il veut mieux mesurer d'abord la dimension de plaque du bassin.

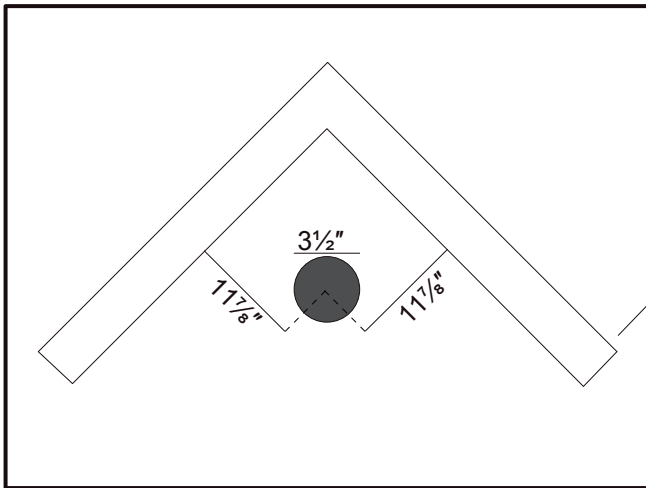

Step 2

Make the drainer channel for the drainer.

N.B.The space between the drainer and walls is 300mm, with the measurement done in advance.

Étape 2

Créer le trou d'égout sur l'emplacement de l'égouttoir.

N.B. la distance entre le trou et le paroi est de l'ordre de 300mm, mesurer pour définir les dimensions concrètes .

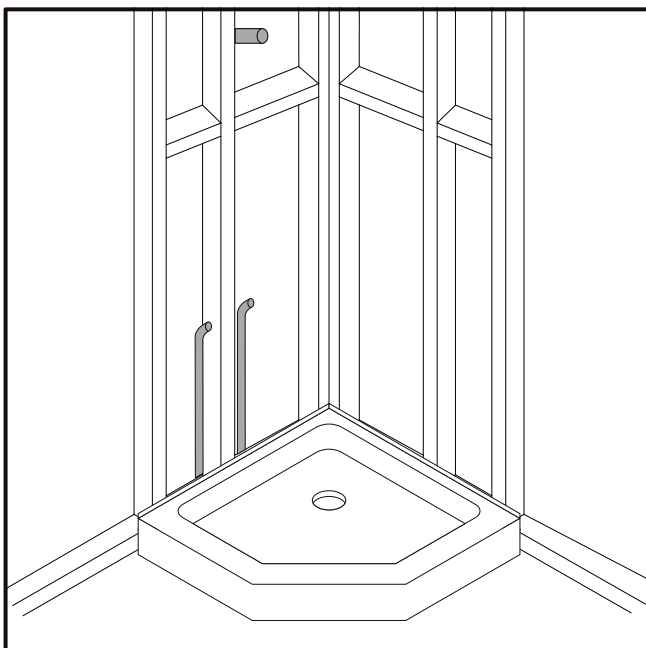

Step 3

Fix inlet hose with the left/right directions chosen firstly. Be sure to connect it with the inlet valve on the back board.

Étape 3

Installation des conduites d'admission , Lors de l'installation des conduites d'admission, choisir la direction, il faut assurer la connexion facile de la soupape d'admission équilibre sur la plaque du dos.

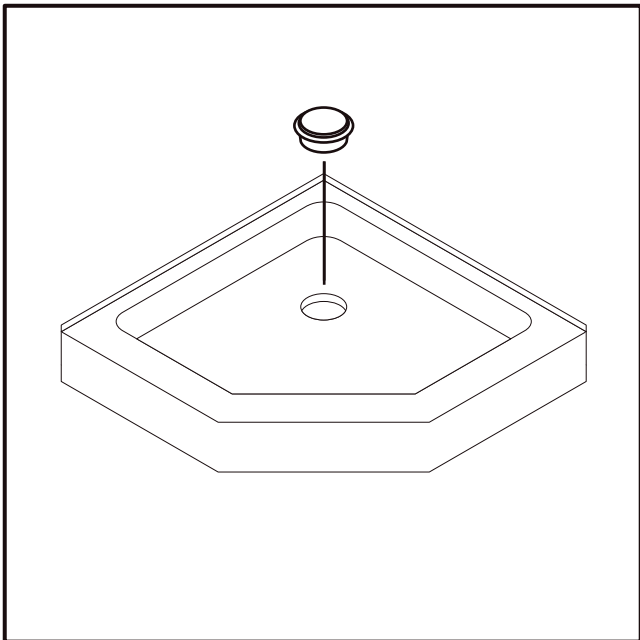

Step 4
Fix the drainer as what the sketch shows.

Étape 4
Comme indiqué, installer l'égouttoir.

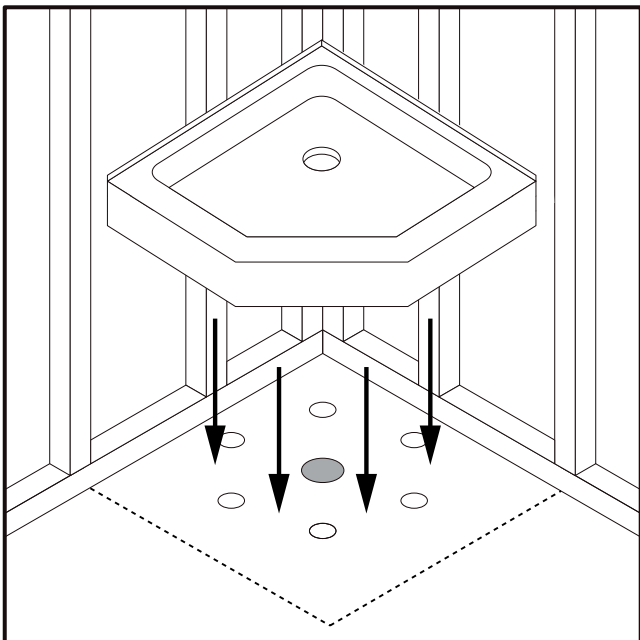

Step 5
Fix the bottom pot with cement or plaster. With the cement or plaster laid on the ground, put the bottom pot on it, with appropriate press to make it leveled.

Étape 5
Fixer le bassin avec ciment à la chaux, D'abord appliquer le ciment à la chaux sur l'emplacement autour de point, ensuite déposer le bassin, appuyer le bassin avec la bonne intensité pour qu'il maintienne le niveau.

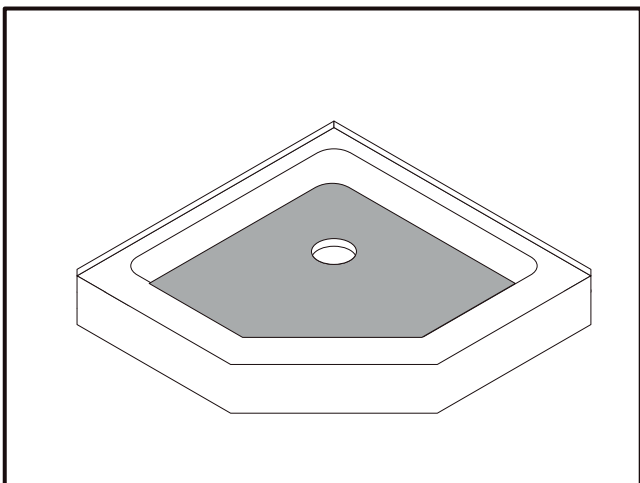

Step 6
After installing the drainer, check it with water. If there is some bubble around it, remake the drainer with good sealing.

Étape 6
Après l'installation d'égouttoir, ajouter l'eau pour tester l'étanchéité du bassin. En cas de la présence de bulles autour de l'égouttoir, il faut réinstaller l'égouttoir jusqu'à son étanchéité soit conformée.

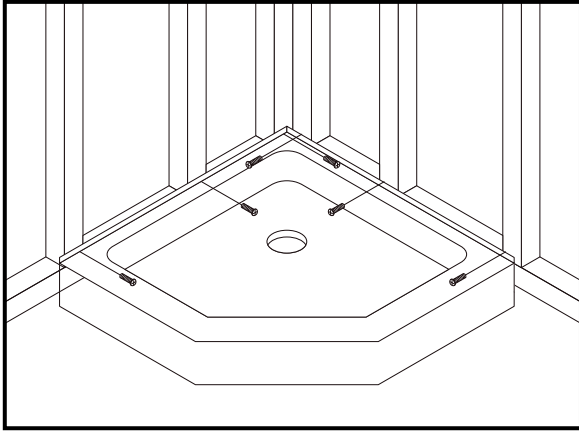

Step 7

Fix the basin with the screws at the bottom pot sides, with the orientation holes made on site.

Étape 7

Fixer le bassin avec vis à coté de bassin.

Choisir l'emplacement de trou selon la situation pratique.

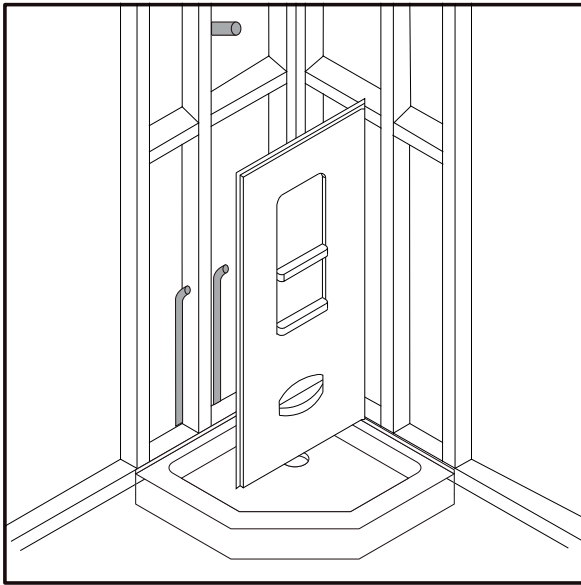

Step 8

Fix the back board with the orientation holes on it for fixing the faucet.

Étape 8

Selon l'emplacement de conduites d'admission, repérer le trou sur la plaque du dos, afin d'installer le robinet.

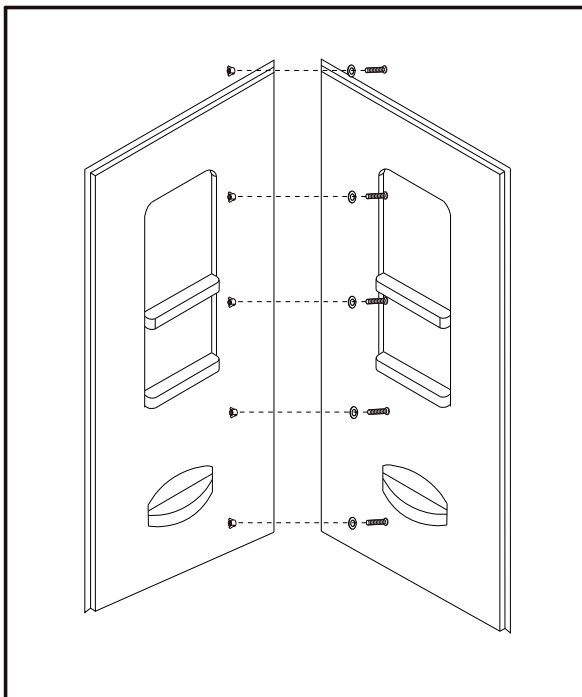

Step 9

Connect the 2 back boards with screws, and fill in the slot with glass cement.

Étape 9

Lier les deux plaques du dos avec vis, remplir les rainures intermédiaires avec la colle de verre.

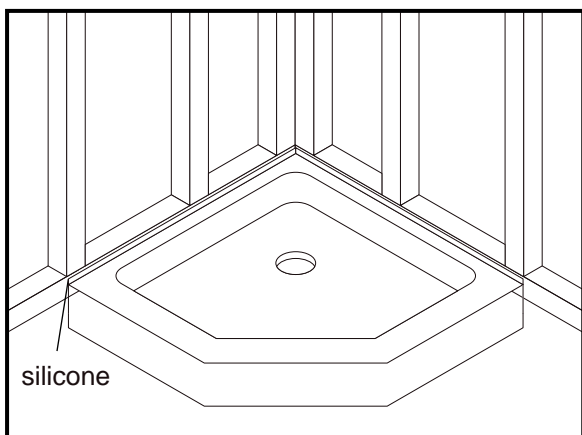

Step 10

Fill in the slot between the bottom pot and walls.

Étape 10

Remplir les écarts entre le bassin et le paroi avec la colle de verre.

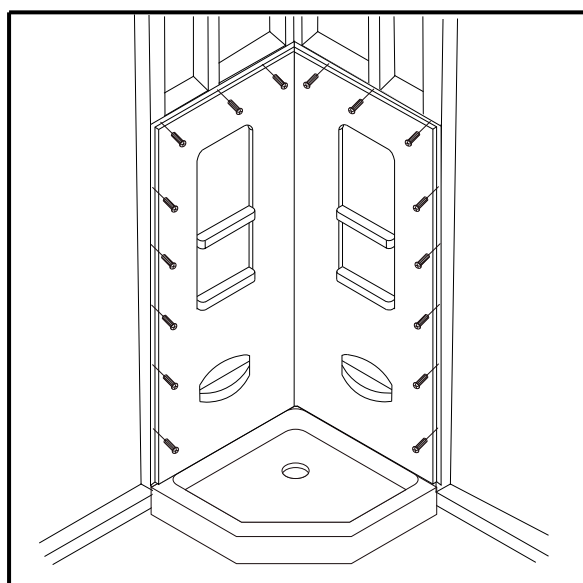

Step 11

Fix the back board on the walls with screws.

Étape 11

Fixer avec vis la plaque de dos sur le paroi.

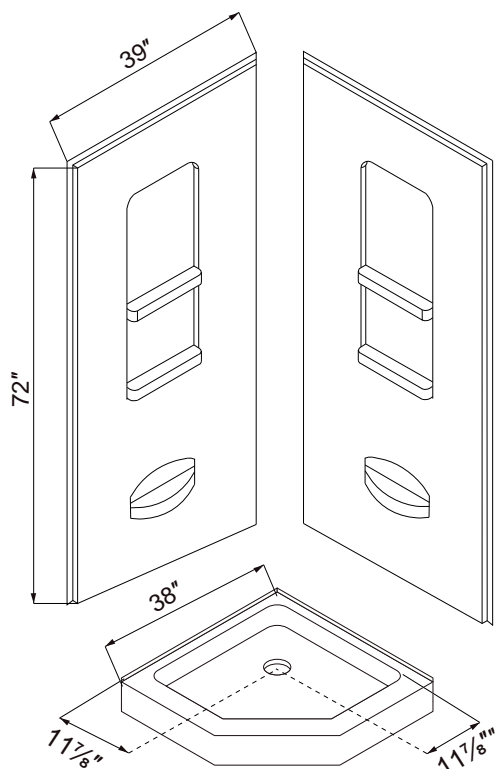

Precautions in Cleaning:

Do not use corrosive detergent. Clean the dirt with a soft cloth. No sharp tool should be used for the cleaning to avoid scratching the surface.

The auto polishing agent can be used with a cloth to clean the scratch for several minutes to recover the brightness.

Notice de nettoyage

Ne pas utiliser les produits de nettoyage ayant l'effet corrosif. Veuillez nettoyer la surface avec un chiffon doux. Ne pas utiliser l'équipement dur et pointu pour nettoyer, afin d'éviter les rayures de la surface.. En cas de traces d'abrasion, utiliser l'agent de frottement pour les véhicules. Appliquer le produit sur un chiffon en coton et frotter l'endroit d'abrasion pendant quelques minutes, de sorte que la surface soit restaurée.