

3. Place two rubber washer(3) under bathtub.

Placez les deux rondelles en caoutchouc(3) sous la baignoire.

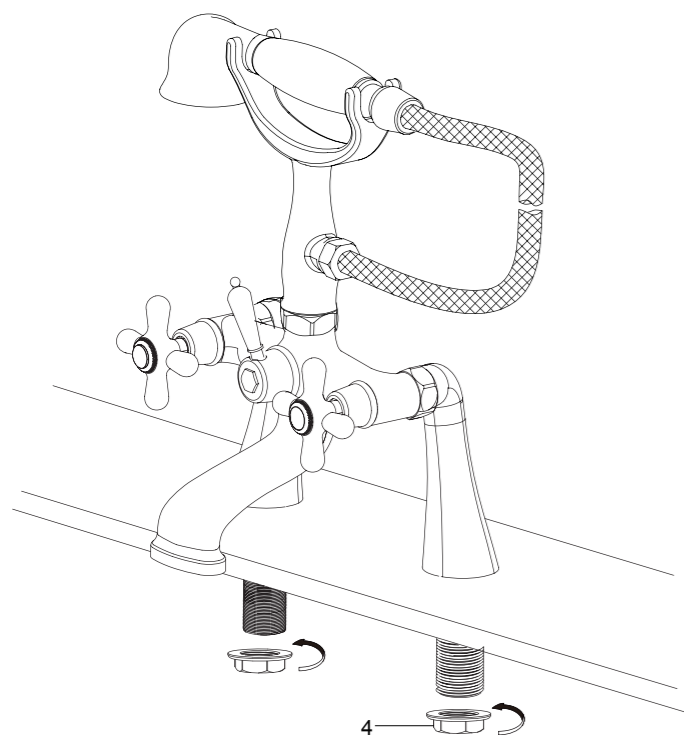

4. Tighten nut(4) onto the water way.

Serrez les écrou(4) sur les tuyaux d'entrée.

M06-8900

CLAWFOOT TUB WATER SUPPLY

Solid brass construction,
Deluxe finish,
6" water way,
1/2" water inlet,
Easy installation.

ALIMENTATION D'EAU POUR BAIN SUR PATTES

Construction de laiton solide,
Fini luxueux,
Voie d'eau 6",
Entrée d'eau de 1/2",
Installation simple.



Tools You May Need Outils requis



Adjustable wrench
Clé à molette



Groove joint plier
Pincés multiprises



Pipe tape
Ruban teflon

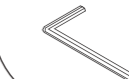

Allen key
Clé hexagonale

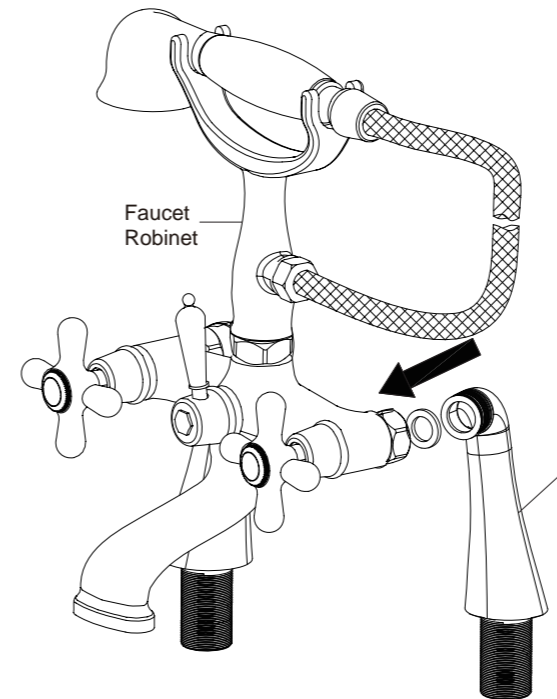
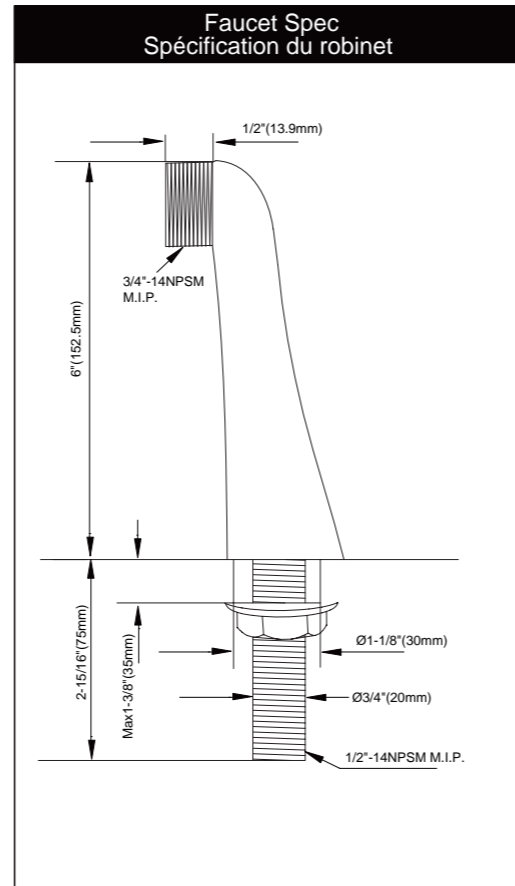
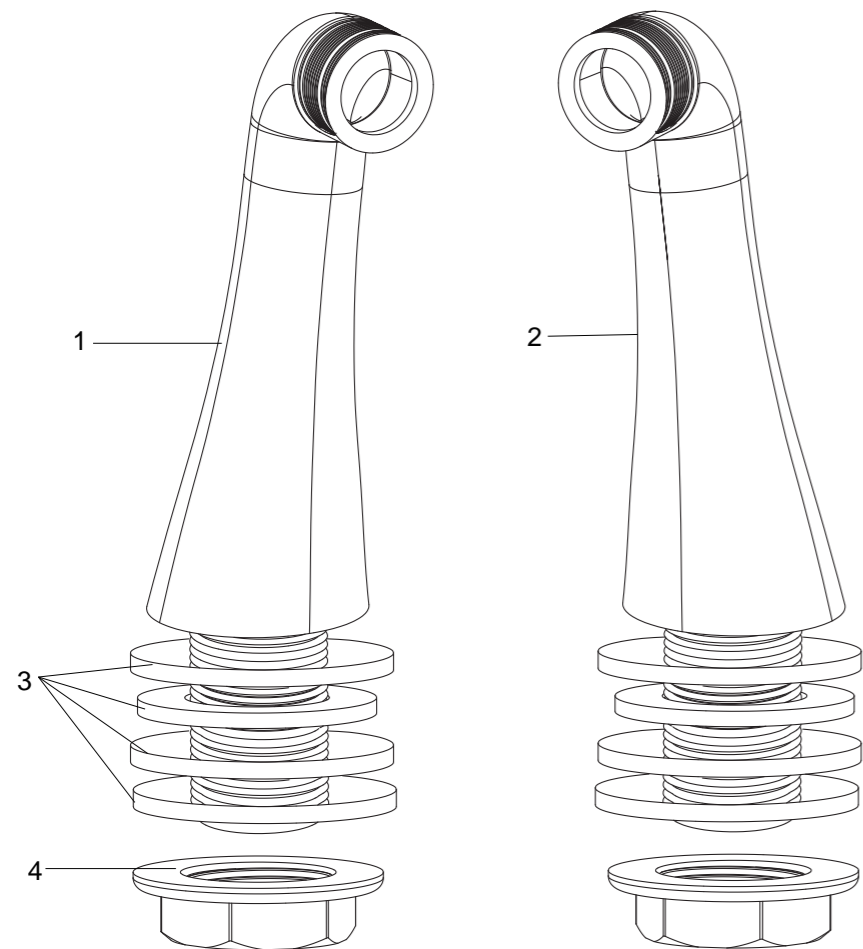

1. Connect two water ways(1) with faucet(not included).

Connectez les deux entré d'eau(1) avec le robinet (non inclus).

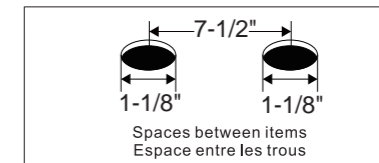

2. Place two rubber washer(3) below water way.
And then put them into the hole.

Placez les deux joints d'étanchéités(3) en dessous des entré d'eau.
Et puis mettre dans le trou.

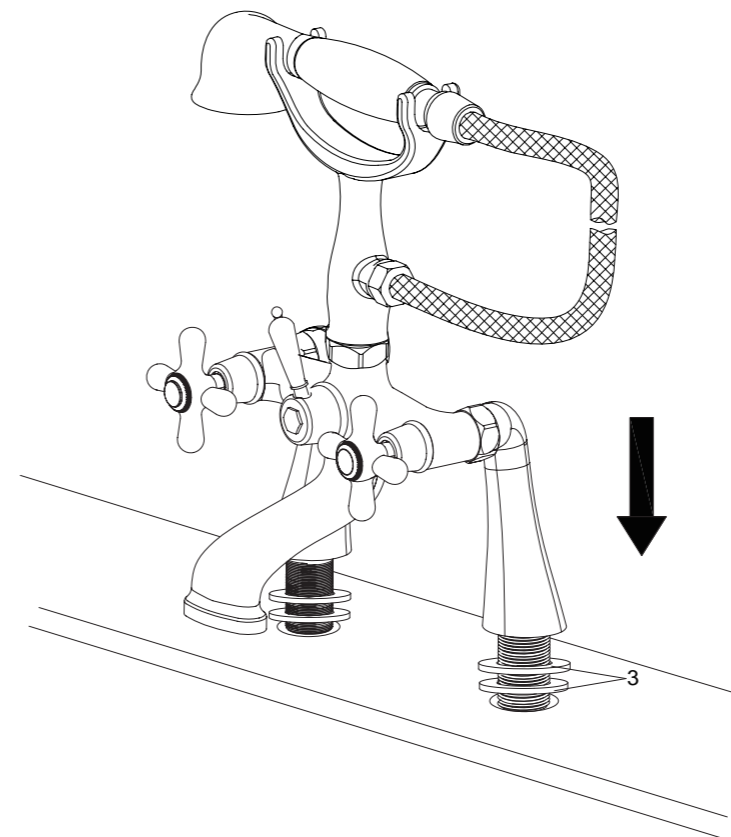

NO Numéro	Description Description	Quantity Quantité	Factory No. Numéro d'usine	RP No. Numéro de
1	Water way (Left) / Entré d'eau (Gauche)	1	P.05.01.012101	
2	Water way (Right) / Entré d'eau (Droite)	1	P.05.01.013101	
3	Washer / Joint d'étanchéité	8	P.10.03.002	
4	Nut / Écrou	2	P.10.12.005016	