



BATHROOM FURNITURE • MOBILIER DE SALLE DE BAIN

Vanity Set • Ensemble meuble-lavabo

19-VF905OAK1-92

Polymarble top
VT-SQ19-02917

Can be drilled 2 extra holes for 4" faucet

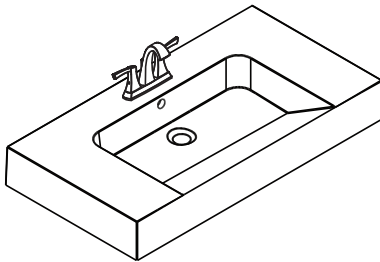

Can be drilled 2 extra holes for 8" faucet

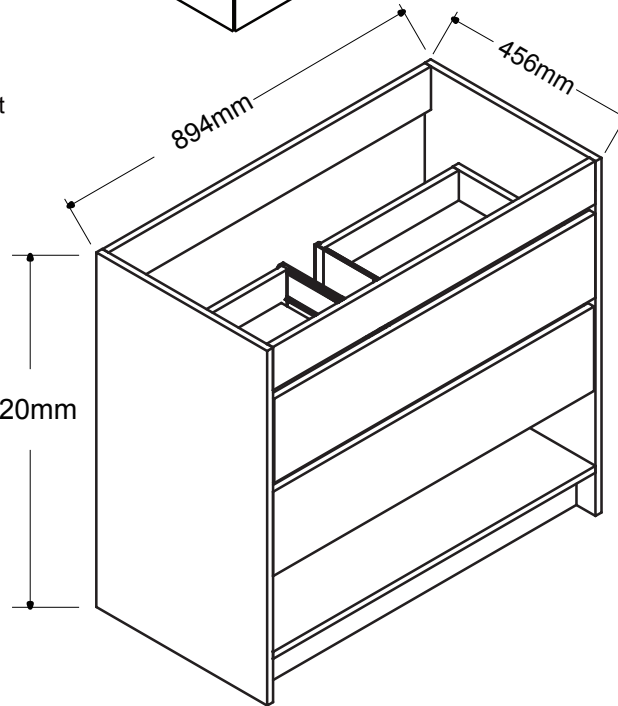
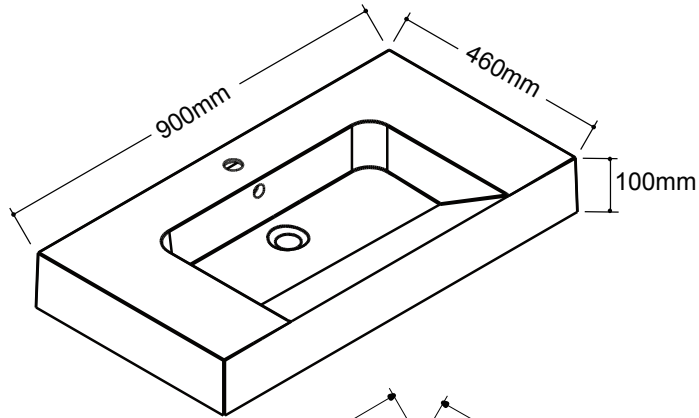
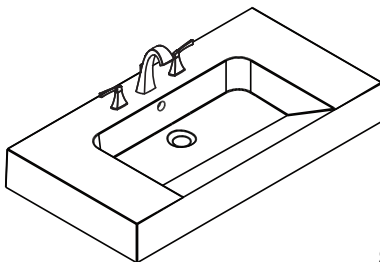

Tools You Will Need - Outils Requis



Power drill
Perceuse électrique



Screwdriver
Tournevis



Pencil
Crayon





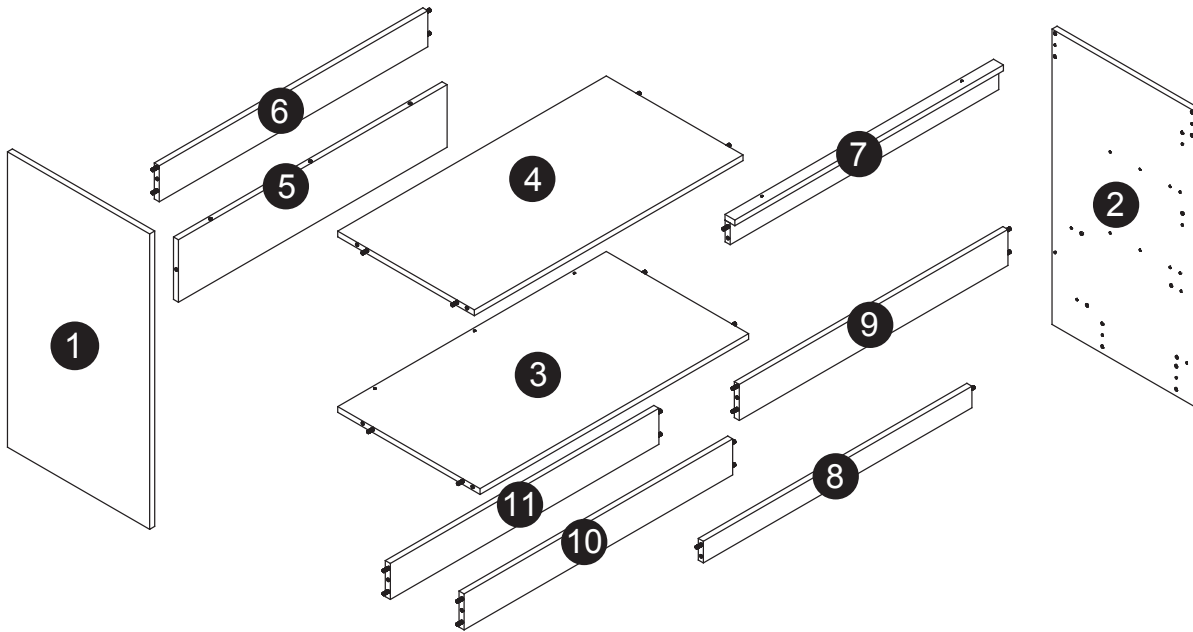

Silicone
Silicone



Size / Dimension:

NUM	DIMENSION / SIZE: W x T x D (mm)	QTÉ / QTY	NUM	DIMENSION / SIZE: W x T x D (mm)	QTÉ / QTY
1	18" x 5/8" T x 32-1/4"	1	9	33-7/8" x 5/8" T x 3-1/8"	1
	456 x 16T x 820			861 x 16T x 80	
2	18" x 5/8" T x 32-1/4"	1	10	33-7/8" x 5/8" T x 4"	1
	456 x 16T x 820			861 x 16T x 100	
3	33-7/8" x 5/8" T x 18"	1	11	33-7/8" x 5/8" T x 4"	1
	861 x 16T x 456			861 x 16T x 100	
4	33-7/8" x 5/8" T x 17-1/4"	1			
	861 x 16T x 439				
5	33-7/8" x 5/8" T x 6-7/8"	1			
	861 x 16T x 174				
6	33-7/8" x 5/8" T x 4"	1			
	861 x 16T x 100				
7	33-7/8" x 1-1/4" T x 3"	1			
	861 x 32T x 76				
8	33-7/8" x 5/8" T x 2-3/8"	1			
	861 x 16T x 60				

Part List / Liste de pièces:

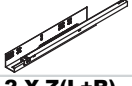
			Master Part :
 28 X B	 28 X C1	 16 X G	B. Metal cam / Vis pour cam-lock C1. Cap for cam-lock / Capuchon pour cam-lock
 2 X P	 2 X Q	 2 X Z(L+R)	D. Screw for base panel / Vis pour panneau de base G. Screw for slides / Vis pour slides P. Plastic plug / Bouchon en plastique Z. Metal drawer slides on side panel / Glissières de tiroirs en métal sur le panneau latéral

Step 1 / Étape 1

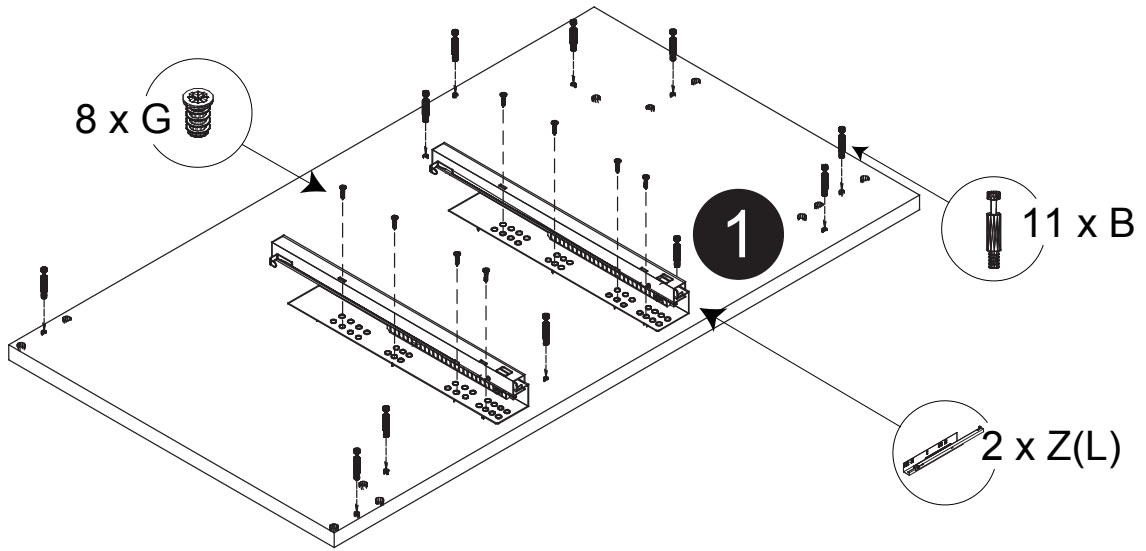

Step 2 / Étape 2

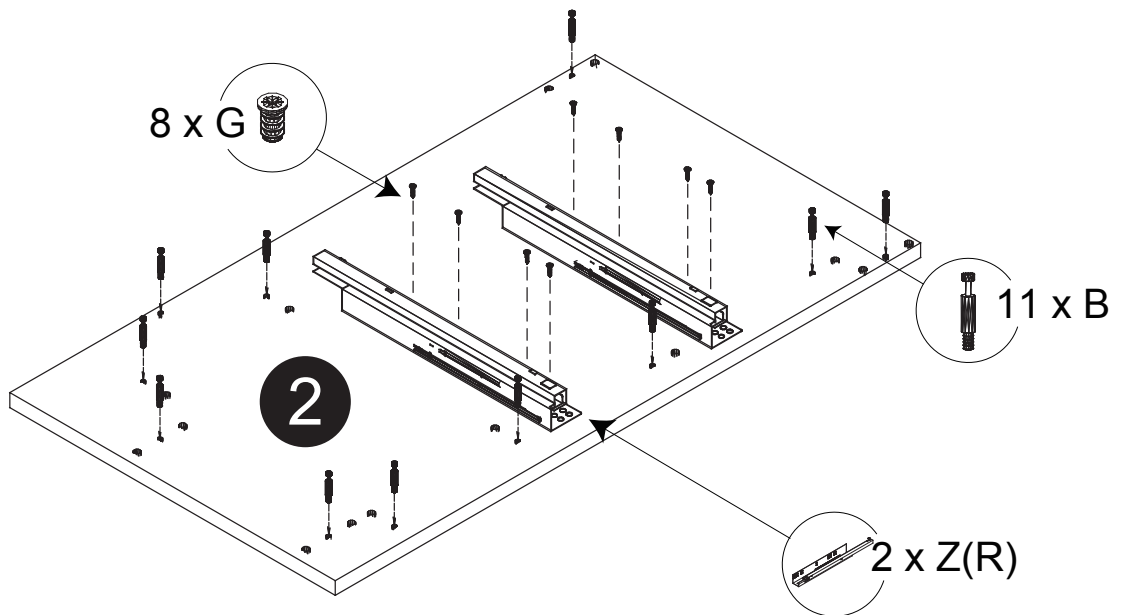

Step 3 / Étape 3

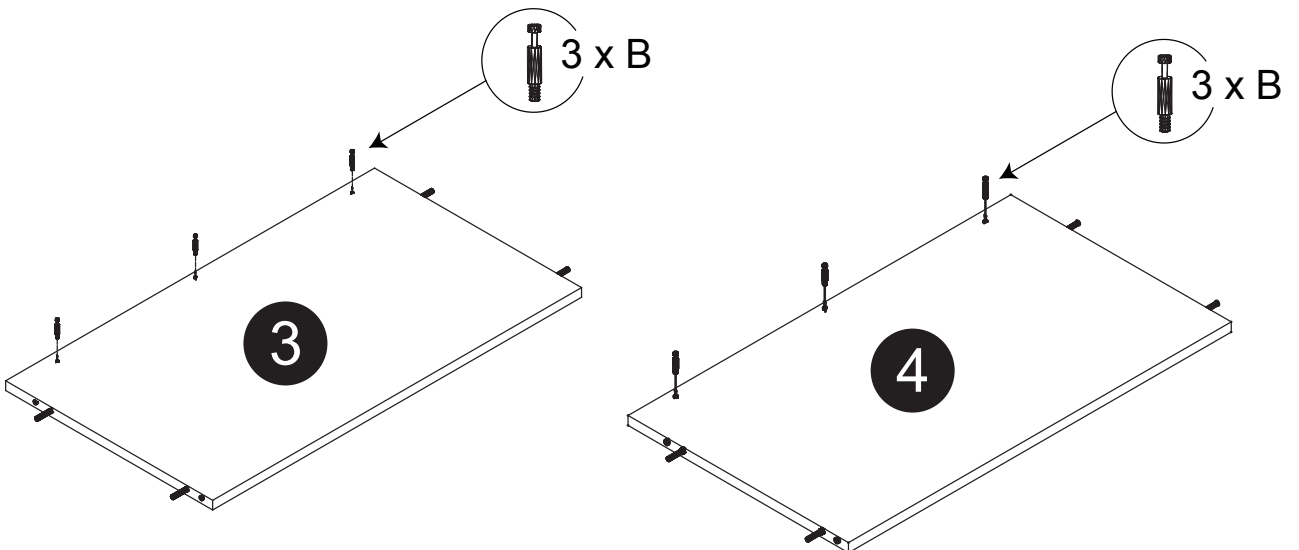

Step 4 / Étape 4

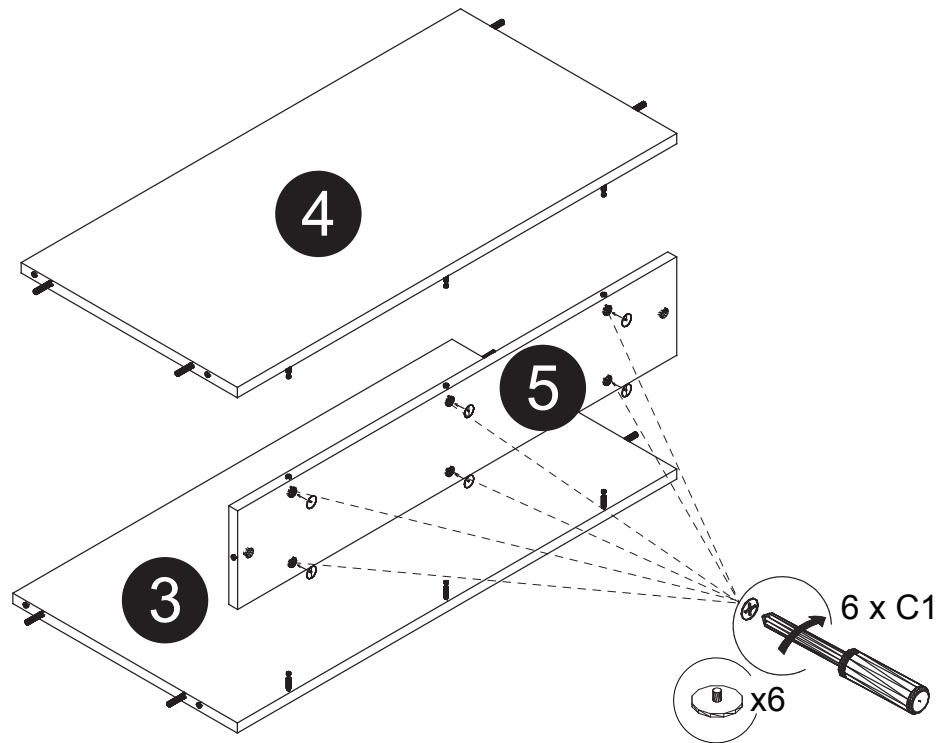

Step 5 / Étape 5

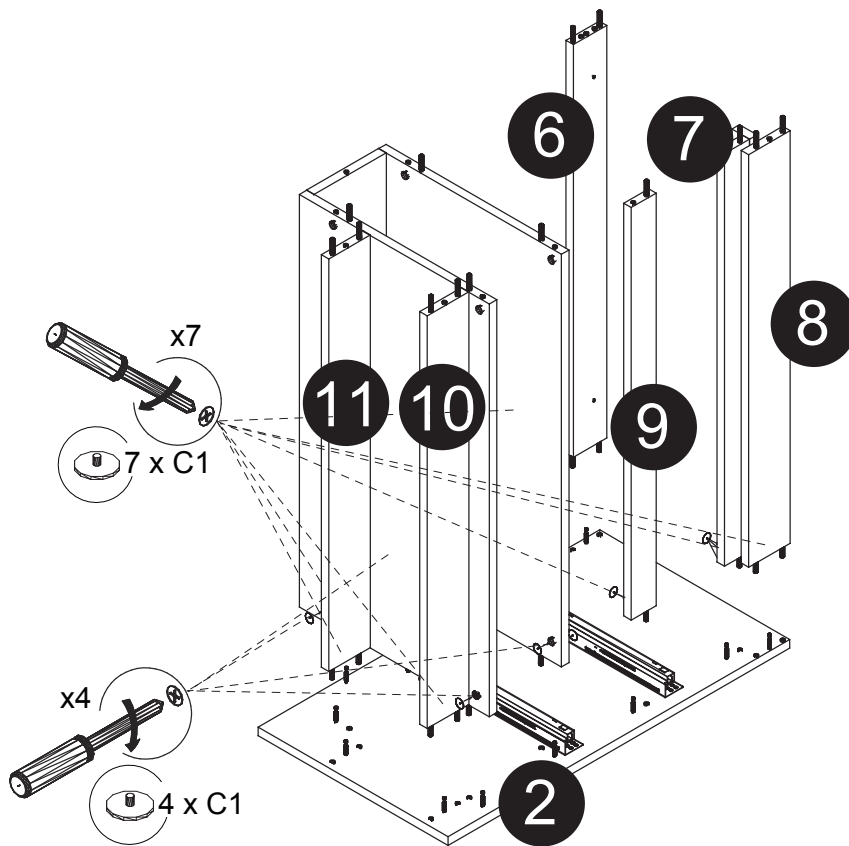

Step 6 / Étape 6

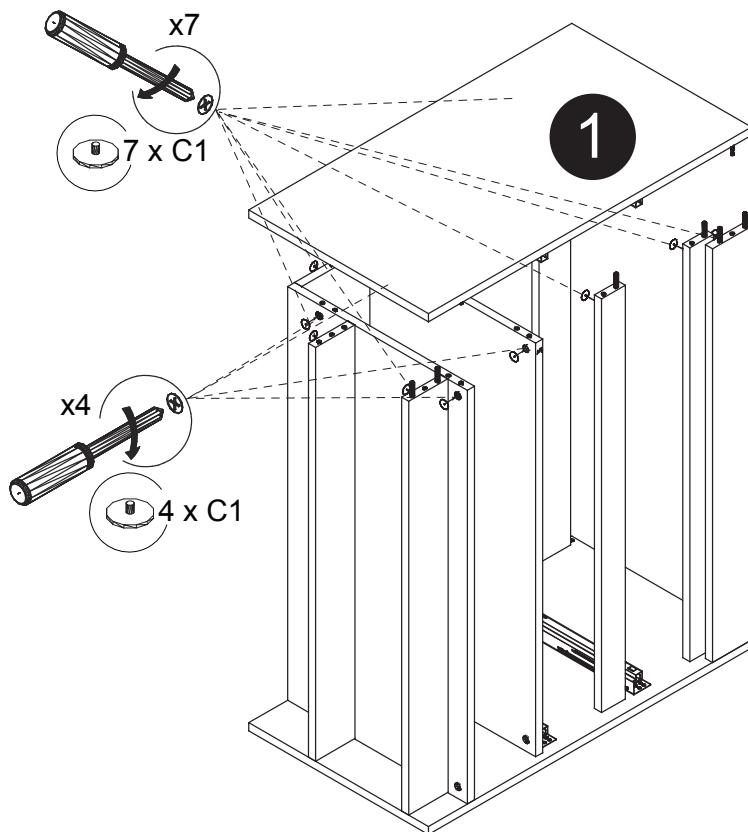

Step 7 / Étape 7

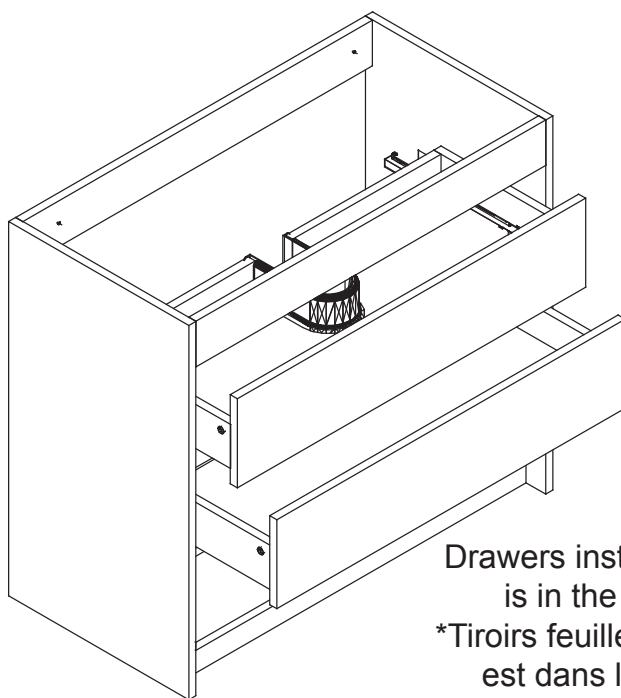

Drawers instruction sheet
is in the other box
*Tiroirs feuille d'instructions
est dans l'autre boîte

The vanity wall mounting screws need to be fixed onto the studs behind the dry wall board. Locate and mark the stud positions with a stud finder, drill pilot mounting holes at marks onto desire studs. Insert the plastic screw sleeves into drilled mounting holes on wall. Drill the screw holes on vanity back panel to match the mounting holes on wall. Install the mounting screws through the vanity back panel, dry wall board to the studs.

*Les vis de fixation murale vanité doivent être fixés sur les montants derrière le panneau mural sec. Repérez et marquez les positions des goujons avec un détecteur de montants, percer des trous de montage pilotes à des marques sur les goujons de désir. Insérez les douilles à vis en plastique dans les trous de montage percés sur le mur. Percez les trous de vis sur la vanité panneau arrière pour faire correspondre les trous de fixation sur le mur. Installez les vis de montage à travers le panneau arrière de la vanité, panneau de cloison sèche sur les poteaux.

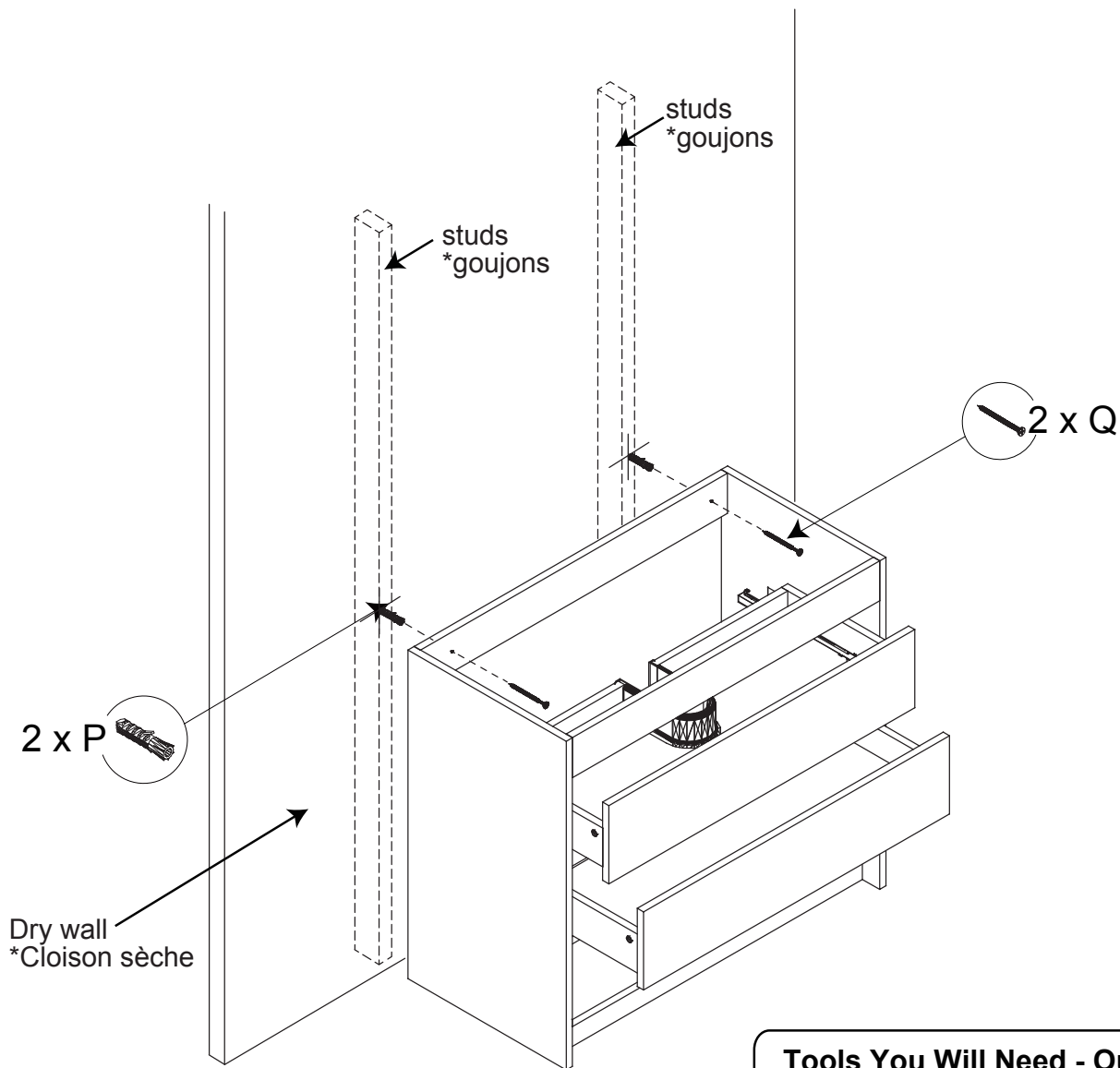

Tools You Will Need - Outils Requis



stud finder
finder stud

Step 8 / Étape 8

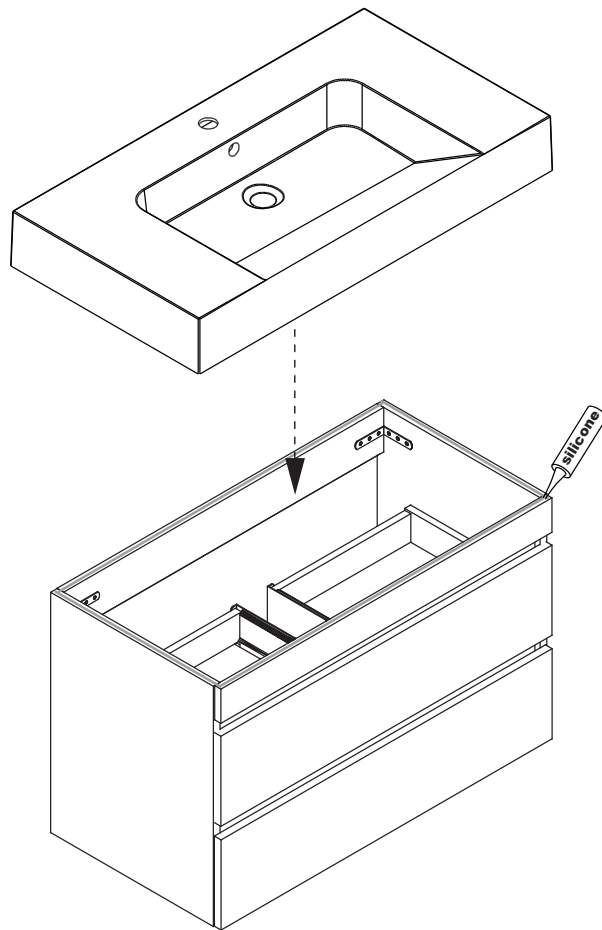

Step 9 / Étape 9

